

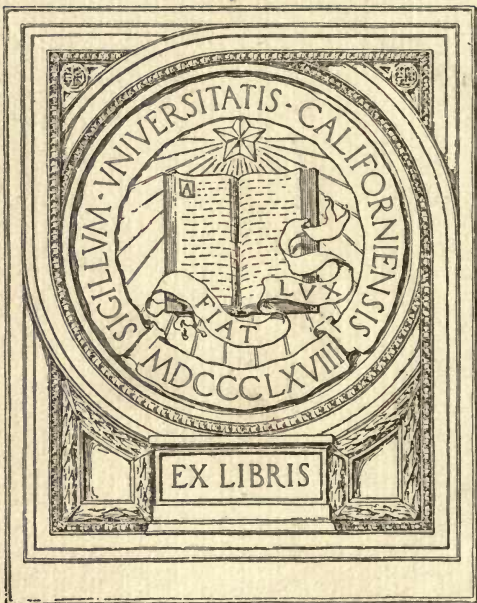

THE CARE OF
A HOUSE
CLARK



EX LIBRIS

THE CARE OF A HOUSE

THE
The  Co.
ESTD

THE CARE OF A HOUSE

A VOLUME OF SUGGESTIONS

TO HOUSEHOLDERS, HOUSEKEEPERS, LANDLORDS,
TENANTS, TRUSTEES, AND OTHERS, FOR THE
ECONOMICAL AND EFFICIENT CARE
OF DWELLING-HOUSES

BY

T. M. CLARK,

FELLOW OF THE AMERICAN INSTITUTE OF ARCHITECTS; FELLOW
OF THE SOCIETY OF ARTS, LONDON

WITH ILLUSTRATIONS



New York

THE MACMILLAN COMPANY

LONDON: MACMILLAN & CO., LTD.

1918

All rights reserved

TH 8901
C6

COPYRIGHT, 1908,
BY THE MACMILLAN COMPANY.

Set up and electrotyped. Published September, 1903. Reprinted
March, 1905; January, 1909; March, 1912; August, 1914; February,
1917.

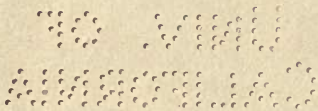

Norwood Press
J. S. Cushing & Co. — Berwick & Smith Co.
Norwood, Mass., U.S.A.

PREFACE

CONSIDERING the importance to happy family life of a comfortable, wholesome dwelling, and the distress, anxiety, and expense often caused by defects which, if understood in season, might have been easily remedied, the writer has thought that a simple explanation of the structure of a modern house, and of the appliances which are attached to it, with descriptions of the disorders to which they are subject, and of the methods of preventing and curing such disorders, might be found widely useful; and he trusts that this little book, in which he has collected, to the best of his ability, such information of the kind as is most frequently needed in families, may be the means of relieving the anxieties and lightening the burdens of some, at least, of the householders for whose benefit it is intended.

22 CONGRESS STREET, BOSTON.

CONTENTS

	PAGE
I. HOW A HOUSE IS BUILT	1
II. THE ROOF	13
III. CHIMNEYS AND FIREPLACES	19
IV. STOVES AND FURNACES	28
V. THE KITCHEN STOVE	34
VI. FURNACES	48
VII. STEAM AND HOT-WATER HEATING	74
VIII. PLUMBING	92
IX. TROUBLES WITH PLUMBING, AND THEIR REMEDY	139
X. GAS-PIPES AND GAS-FIXTURES	188
XI. ELECTRICAL FIXTURES	198
XII. THE CARE OF WOODWORK	209
XIII. KEEPING A HOUSE IN REPAIR	258
INDEX	279

THE CARE OF A HOUSE

CHAPTER I

HOW A HOUSE IS BUILT

NOTWITHSTANDING all that is said about the preference of Americans for hotel life, and the multiplication of apartment-houses, flats, family hotels, and other contrivances for leaving a portion of the housekeeping troubles to the janitor, the disposition toward independent home life increases in this country every day. There are few tenants of apartment-houses who do not look forward to the time when they can have a home of their own; and those who possess that blessing, however much they may repine at the anxieties attending it, are seldom contented to give it up permanently. It may be assumed, therefore, that the independent dwelling is likely to continue to be favored by the great majority of American families; and, in view of the complexity of modern houses, it seems as if something might be done to lighten the burden of those who have the care of them by a simple explanation of their construction, and of the principles of operation of their different working portions. Nothing is more trying to the nerves than to have to deal

with troubles, the source of which is unknown; and a very moderate knowledge of the general construction of a house, and of the elements of heating and plumbing apparatus, would relieve many a housekeeper from hours of exhausting worry, to say nothing of the saving of money which might often be made through the indication which such knowledge would afford of the source of any of the numerous troubles to which houses are subject, and of the nature of the remedy which should be applied.

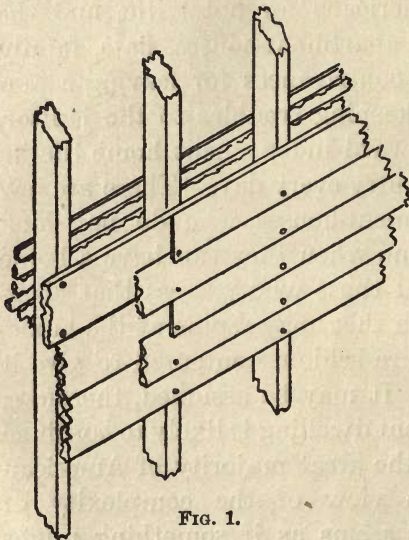

FIG. 1.

Most houses in North America are built of wood, the walls consisting of a frame of studs, or light timbers, set, usually, sixteen inches apart from centre to centre, and covered on the outside with rough boards, which, in their turn, are covered with clapboards, or, sometimes, with shingles. On the inside of the studding laths are nailed, and covered with plaster; and the interior partitions are made with similar studding, covered on both sides with laths and plaster (Fig. 1).

The studs of the outside walls stand on a heavy timber, called a sill, which rests on the top of the cellar wall, or, where there is no cellar, on an underpinning of stone or brick, or on stone or brick piers, or on wooden posts; and at the top of the walls is a "plate," or horizontal piece, on which rest the lower ends of the "rafters," or roof timbers. The rafters are usually spaced from twenty to twenty-four inches apart, and are covered with boards, and these with shingles. The studs of the main interior partitions in the first story usually stand on "girders," or heavy timbers, set either level with the beams of the first floor, or just below them, and supported by brick piers in the cellar. The studs of inferior partitions, which carry little or no weight, and of partitions in upper stories, are set on the floors, and openings are framed in both outside and inside studding for doors and windows. The floors are formed with beams, or planks set on edge, usually from eight to ten inches deep, and two or three inches thick, set most commonly sixteen inches apart, from centre to centre, and resting on the sills, girders, and main studding of the house. The floor-boards are nailed on top of the beams, and the under side is usually prepared for plastering by nailing on "furring strips," these being long strips of wood, two inches wide, and seven-eighths of an inch thick, put on twelve inches apart. The laths are nailed to these furring strips, and the plaster is spread on the

laths. It is obvious that the floor-beams, laid in parallel lines, and covered with boards above, and with a sheet of plastering underneath, will form a succession of hollow spaces (Fig. 2) of the same depth as the beams, and thirteen or fourteen inches wide; and these spaces are utilized by

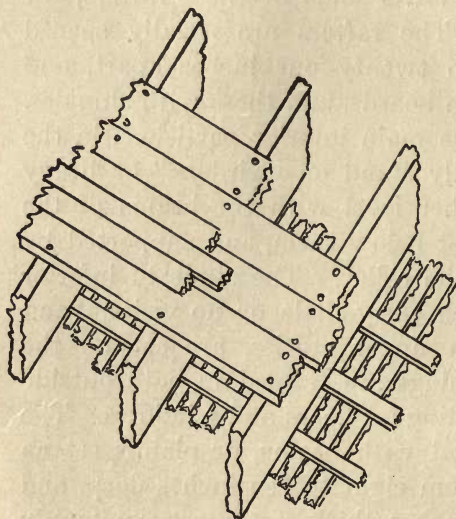

FIG. 2.

builders for containing hot-air pipes from furnaces, plumbers' pipes, gas-pipes, and electric wires.

It is, therefore, often important, in tracing a leak, or on other occasions, to know the direction in which the floor-beams run. This can

generally be ascertained by observing the direction of the floor-boards, which usually, although not always, run at right angles to the beams, as shown in Figure 2. Where there is any doubt on this subject, further evidence may be derived from observation of the ceiling beneath. Most ceilings, particularly over a chandelier, or steam radiator, or register, become slightly dis-

colored by smoke and dust. As plastering is very porous, air, impregnated with these impurities, passes easily through it, and the impurities are filtered out, staining the plaster. As the air cannot penetrate the laths, transmission takes place mostly between them, so that the spaces between the laths are marked on the ceiling by a narrow dark line, the plastering just over the laths remaining white. The furring strips, to which the laths are nailed, appear as broader streaks of white at right angles to those indicating the laths; and, as the furring strips must be nailed at right angles with the beams, the laths will be parallel with the beams, and the direction of the latter will thus be shown. In very cheap houses there are sometimes no furring strips, and the strips are often omitted on basement ceilings. In this case the laths will run at right angles with the beams, instead of being parallel with them; but the two cases can usually be distinguished by measuring the distance between the wider white streaks which indicate furring strips or beams. If the streaks are twelve inches apart from centre to centre, they show, in all probability, furring strips, and the laths run parallel with the beams; if they are sixteen inches or more from centre to centre, they probably indicate beams, and in this case the laths run transversely to them. The direction of the floor-boards will confirm these indications, which are often of great importance.

City houses.

City houses are constructed in very much the same manner as country houses, with stud partitions and wooden beams; but the beams rest at their outer end on brick walls instead of studding.

Structural diseases.

This structure, of beams, studs, rafters, and stone or brick walls, is liable to various kinds of deterioration, and the symptoms of such deterioration should be known, in order that the disease which they indicate may be treated before it becomes serious. In a brick house settlements of the walls may take place, due, usually, to inadequate foundation. Such settlements are indicated by cracks, the direction of which is, as a rule, approximately at right angles with the direction of the settlement; so that, by drawing lines perpendicular to the general direction of the cracks, the position of the yielding portion of the foundation can generally be found, and the trouble remedied in such manner as circumstances may require.

In a wooden house, the weight of which is trifling in comparison with that of a brick one, settlements, which will show themselves by cracks in the interior plastering, rather than by dislocations of the outside clapboards or shingles, are less likely to proceed from the failure of the foundation than from rotting or shrinkage of the timbers, or from their insufficient strength. Settlement from rotting of timbers occurs most commonly in old houses, and manifests itself first, as a rule, in the outside walls, the studs of

which stand on the sill. As the sill rests on the stone or brick underpinning, which is often damp, particularly in old houses, where the ground outside is frequently graded up so high as to cover the underpinning, and even portions of the sill, the latter soon begins to rot on the under side; and, when the disease has progressed far enough, the timber slowly gives way. When this happens, the studs resting on the decaying timber sink, and the disorder is betrayed by the cracking of the plastering incident to the movement. In building new houses, the rotting of the sill can be postponed for many years by painting the under side with a coat of any cheap paint which will repel the dampness of the stone or brickwork on which it rests; but in old houses, where it has already occurred, the remedy is to cut out the old sill, or such portions of it as may be decayed, and put in fresh timber, which can be done with little difficulty if settlement has not progressed too far.

Defects due to shrinkage show themselves, in **Shrinkage.** general, within two years after the completion of the house, when the timber has been dried by the furnace fires or steam heat of one or two winters. As all wooden houses are now framed with green timber, a shrinkage of at least a third of an inch must be expected in every floor timber of average depth; and where a girder rests on piers, and floor-beams on the girder, the combined shrinkage of the girder and the beam may

be two-thirds of an inch. If, then, as often happens, a partition is secured at one end to the framing of an outside wall, which shrinks very little, if at all, and is supported at the other end by a beam, resting on a girder, and exposed to the dry air of the house, this end will, by the shrinkage of the beam and girder, settle half an inch or more, distorting the openings, causing the doors to bind, and cracking the plastering.

Where beams, girders, and stud partitions are superposed through several stories, the shrinkage accumulates, so that cracks in plastering, and other marks of settlement, are always worst in the upper story of a house. A skilful architect can frame a house so as nearly to eliminate settlement from shrinkage, or, at least, to make it uniform, so as not to distort the partitions; but, if this has not been provided for in the original construction, no remedy can be applied. Fortunately, settlement from shrinkage reaches its limit in a few years, and the cracks can then be stopped up.

Weakness
of timbers.

Settlement from weakness of timbers is a much more serious affair. It can usually be distinguished by the bending of floors, or ceilings, or girders, at the weak point; and, unless checked, will continue to increase indefinitely. The only remedy is the application of supports to relieve the overstrained beams or girders; and these supports may take the form of additional piers under girders, or extra timbers, braces, or arches under floor-beams; but they should be applied at once.

Apart from the dislocations proceeding from settlement, all houses with wooden floor-beams and partitions are liable to cracks in the plastering due to other causes. The most serious of these come from the deterioration, or original bad quality, of the plastering itself. In most houses the plaster is spread on wooden laths, about one and a half inches wide, and three-eighths of an inch thick, nailed to the studding or furring strips, with a space between them, which should be three-eighths of an inch wide, or just the thickness of an ordinary lath. The mortar for the first coat of plastering on laths is mixed with hair, or, occasionally, with wood fibre. When applied to the laths, and pressed against them by trowelling, the soft mortar is forced

Defects in plastering.

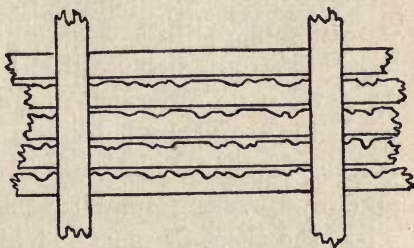

FIG. 3.

through the spaces between them (Fig. 3), and bends over, forming, when hard, hooks, or "keys," or "clinches." The mortar, after drying, does not adhere to the laths, and the keys or clinches are all that holds the sheet of plastering in place; and, as the plastering mortar, when dry, is brittle, even that would be insufficient if it were not for the hair or other fibre mixed in it to give it the necessary tenacity. Inferior plas-

terers, to save the mortar which forms the clinches, put on the laths one-fourth of an inch apart, or even less. The trowelling then fails to push the soft mortar through the space in sufficient quantity to bend over, and much less mortar is used; but the result is that the wall or ceiling, when finished, has little or nothing to hold it to the laths, and when these dry and shrink, as they soon do, the plastering separates from them, bulging out from walls, or "bagging" down from ceilings. Even where the plastering was originally good, the shaking incident to walking or running over the floors above will, in the course of years, break off the clinches of ceilings, allowing the plastering to separate from the laths. In either case fine cracks can be observed, running at random over the ceiling, and, by holding a straight rod under it, the plastering can be seen to have "bagged"; and, by pressing it with the hand, or with a stick, the sheet of plaster, which, having left the laths, is supported only by the tenacity of the hair in it, can be felt to yield. A plaster ceiling which has left the laths in this way is not necessarily in a dangerous condition. If originally well made, with plenty of good hair, a sheet of plastering mortar of considerable extent may hang for several years without support from the laths; and, as the breakage of the clinches goes on progressively over a ceiling, it may be a long time before the whole is affected. When, how-

ever, the bulging becomes very marked, and the bulged portion is much cracked, it is liable to fall, and should be taken down, the old mortar picked out of the spaces between the laths, and the ceiling replastered; or, still better, the old wooden laths taken off, and the ceiling replastered on metal lath, which will hold the mortar indefinitely.

Another, but less serious cause of cracks in plastering is the shrinkage of the laths. The lathers, to save themselves trouble, often change the direction of a few laths on a wall or ceiling (Fig. 4), instead of cutting short pieces, and putting them on parallel to the general direction of the lathing. Every such change of direction causes, later, a crack in the plastering over it; and similar cracks are common at the corners of door openings, where, unless special

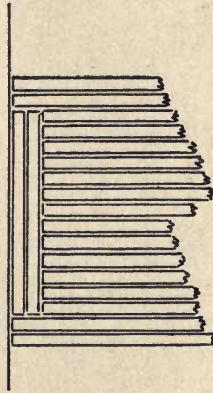

FIG. 4.

precautions are taken in lathing, the shrinkage of the heavy studding around the doors affects the plastering. Still other cracks are often seen in the plastering around chimneys, due to the settlement of the brickwork of the chimney, which, as the mortar in the joints dries out, settles slightly away from the wood framing around it. A different set of cracks is usually to be observed

around staircases, which, owing to the peculiar character of their framing, settle much more by the drying and shrinkage of their supporting timbers than the work about them. The same may be said of plastering in attic rooms, where, owing to the special effect of shrinkage on the rafters, and other members of the roof-framing, cracks are almost inevitable. In all these cases, however, they are of no serious consequence, involving, at most, only an occasional filling with plaster of Paris.

CHAPTER II

THE ROOF

As the plastering of walls and ceilings usually gives, by cracking, the first indication of settlement, shrinkage, or decay in a house, so it also commonly reveals, by stains, the leaks in roofs, or around windows and skylights, which constitute, perhaps, the most distressing, because most unaccountable, troubles of the householder. The best of all roofs is one covered with the plain "shingle" tiles so universally used in Europe. For the American climate, with its violent winds, drifting snow-storms, and intense frosts, often following a warm rain, the tiles should be hard-burned, or "brown," as they are called in England, and laid in cement; and, as the tiles are heavy, comparatively strong rafters are needed to support them; but such a roof, with copper flashings where necessary, will often endure for centuries, and is practically fire-proof. Slate roofs, which also rank as fire-proof, are very inferior to those covered with tiles. The slates are brittle, and, as they are nailed, instead of being hung, like tiles, to strips laid on the roof, it is difficult to nail them tightly enough to prevent them from shaking in high winds, and breaking off at the nail

Tile roofs.

Slate roofs

holes, without driving the nails occasionally a little too tightly, and breaking the slate in this way. In either case, a slate broken at a nail hole causes a leak, and there are few slate roofs which can endure a winter's storms without some breakage. Shingles are not disposed to break by shaking in the wind, or by being nailed too tightly, and form, so long as they last, a much better roof than slates; but they soon rot in the "valleys," or angles between intersecting portions of the roof; and inferior shingles may split or curl in the sun, also causing leaks.

Shingle
roofs.

Where the pitch, or angle with the horizontal, of any roof covered with shingles, slates, or tiles is too low, drifting snow will blow up under them, unless they are laid in cement, and melt there, often causing a small leak; and the shingles on low-pitched roofs soon rot out on account of the slowness with which rain-water drains away from them. The minimum pitch for such roofs should be $26\frac{1}{2}$ degrees, or "quarter-pitch," as the carpenters call it, the rise of the roof being one-fourth of the span, and a higher pitch is much to be preferred; and, unless the pitch is very steep, shingles, or slates, or tiles, should be put on over two layers of waterproof felt, tacked to the roof-boarding.

Pitch of
roofs.

For covering flat roofs, such as are commonly found in city houses, and often in those in the country, copper, tin, or composition may be used. A copper roof is very costly, but, if not injured

Flat roofs.

by walking over it, will last a lifetime. Tin roofs do well inland, but are not very durable near the sea, and they must be kept well painted to preserve them. Composition roofs, made with tarred felt, in two, three, four, or five layers, mopped with melted tar, and covered with gravel, are cheap, and good while they last, and are easily renewed.

It is obvious that neither slates nor shingles will fit water-tight against each other, or against chimneys or walls; and, to protect junctions of this sort, flashings are used, consisting of strips or pieces of lead, zinc, tin, or copper, the general principle of their application being that the lower edge laps over the roofing, so as to throw rain-water safely away from the joint, while the upper edge is inserted tightly into a groove in the wall or chimney, so that water running over the surface of the latter will continue down over the metal, and will be thrown out upon the roofing; or, in the case of flashings in valleys, the strips or pieces of metal are so arranged as to receive the rain-water flowing down over the slates or shingles on each side of the valley, and conduct it to the gutter. In practice, however, flashings, to save metal, are usually made too narrow, so that water, in heavy rains, overflows them, and runs into the rooms below. In the case of chimney flashings, the metal often warps out of its groove, so that the water runs down behind it; and zinc or tin flashings in valleys in

Flashings.

time corrode, and allow the water which runs down the valley in storms to escape into the house, causing a very bad leak.

An examination of the wet spot in the plastering caused by a leak in the roof will generally indicate the source of the trouble. If it is near a chimney, or, in a city house, near either a chimney or a brick wall, or in the neighborhood of a skylight or scuttle, it is probably due to defective or too narrow flashing at that point. If, in a house with a pitch roof, with intersections of dormers or other roofs, it appears under a valley, it is probably due to the deficiency, corrosion, or displacement of the valley flashing, or to the rotting of the shingles in the valley. If the roof is flat, and the wet spot is large, and is not near a wall, chimney, or skylight, it probably comes from defects in the roofing itself, such as holes in a tin roof, caused by corrosion, or by walking over it, or shovelling snow from it, or, in a composition roof, from dry, spongy places, due to the long-continued action of the weather. Such leaks in tin roofs can be mended with a drop of solder. Leaks in composition roofs may sometimes be patched, but roofing of this kind does not often show defects until it is so extensively decayed as to need entire renewal.

Minor wet spots in plastering often occur, after heavy rains, from other causes than leaks in the roof. Gutters are not infrequently so arranged that, if choked with leaves or ice, they overflow

into the house; and it often happens in winter that snow and ice freeze to the lower edge of a roof, where it projects beyond the walls, and is thus out of reach of the warm air of the house, and the border of ice thus formed around the roof intercepts the water descending from the melting of snow lying on the warmer portions of the roof above, and causes it to back up under the shingles or slates until it finds its way into the inside of the house. Windows, also, in wooden houses, are vulnerable features, and, unless the top of the upper outside casing is protected with sheet lead, as it always should be, but often is not, water will drive in during heavy rains, and show itself inside at the edges of the casings, or will drip through the top of the frame, and stain the curtains and shades; while the rain-water which runs over the glass, collecting on the outer sill, will often blow through to the inside, staining the plastering or paper beneath the window.

From whatever cause they proceed, wet spots in plastering indicate defects which should be attended to immediately, to prevent further damage. Flashings, broken slates, and rotten shingles can only be attended to by a roofer or carpenter, and the roofer employed for the purpose should be thoroughly reliable, as it is a common trick among the inferior ones, when employed to make repairs, to loosen sound flashings, or break good slates, so that they may have another

Repairs.

job when the next rain-storm comes. The trifling leaks which occur around windows in driving storms can generally be cured with paint, mixed thick, and pushed into the crevices with a putty-knife, or with thin sheet lead, tacked on where necessary.

CHAPTER III

CHIMNEYS AND FIREPLACES

IF the roof is kept tight, and the walls thoroughly painted, with good materials, at intervals not too long, a wooden house should not give much trouble by leakage, but the fireplaces and chimneys will often cause anxiety. All houses have brick chimneys, and most houses have also brick fireplaces, with brick hearths, covered with tiling or not, as the case may be. All these may show defects, and the chimney above the roof is sure to deteriorate, by the weathering of the mortar, which rapidly decays under the influence

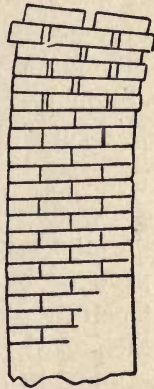

FIG. 5.

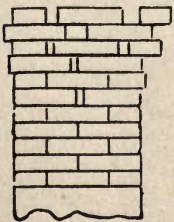

FIG. 6.

of rain and frost. If the chimney-stack rises high above the roof, the effect of the weathering will be first seen in the bending of the stack toward the quarter from which the rains come (Fig. 5); and, if this is allowed to go too far, the stack may fall. If the chimney is short and stout, it will not bend, but the upper bricks will become loose (Fig. 6), and may

fall down the flues, causing a stoppage which can be remedied only with great difficulty; so that all chimneys should be watched, and the upper portion rebuilt as soon as signs of decay appear. As in the case of roofers, only thoroughly trustworthy masons should be allowed to touch a chimney, and any portions rebuilt above the roof should be laid in clear cement.

Inside the house, the chimneys and fireplaces may also give trouble. The old practices of building chimneys on the floor-beams, or leading them obliquely around a house, resting on pieces of joist, are now generally abandoned, and a modern chimney usually stands erect on its foundations, so that it is not likely to crack open or collapse; but the flues may be too small, or otherwise improperly built, and give annoyance in consequence. Open fireplaces require large flues, at least 8×12 inches for a fireplace of ordinary size, built separately to the top. If they are smaller than this, or if they are contracted at the top, as is sometimes done in pursuance of a mistaken theory, or are in any other way obstructed, the fireplaces will smoke; and if a fireplace flue is united with another flue before it reaches the top of the chimney, as is often the case in cheaply built houses, the smoke from a newly built fire will ascend one of the flues and descend the other, coming out in the room to which the latter belongs.

Flues.

Remedying
defective
flues.

It is not an easy matter to remedy a defective flue. If it has been contracted at the top, this

portion can be taken off and rebuilt properly ; and, occasionally, a partition can be built between two flues which unite only at the top, or a partition of sheet iron can be inserted ; and obstructions in the flue may be sounded for with a heavy iron ball, attached to a string, and, if the trouble is caused by loose bricks or mortar, caught in the flue, they may often be dislodged by pounding them with the ball.

If the flue is hopelessly too small for an open fireplace, it can often be utilized for a stove. Even an open stove will work well with a much smaller flue than would be required for a fireplace, for the reason that the smoke and gases from a stove are hotter and more concentrated than those from a fireplace, and, in consequence, ascend more rapidly and in a smaller space. A close stove, for similar reasons, will work with a flue still smaller than that required for an open one.

Even if the flue is properly built, large enough and high enough, it may be exposed to down-draughts from neighboring hills, or buildings, or roofs, or even trees. It is a peculiarity of air in motion that it clings tenaciously to the surfaces over which it passes, following their irregularities ; and a current of wind, meeting a hill, or building, or roof, or other obstruction, climbs up one side of it, and climbs down the other ; and, if the top of a chimney-flue happens to be in the descending current, a down-draught will be caused when-

Down-draughts.

ever the wind blows from the obstruction toward it. A defective draught in a chimney, due to this cause, can be distinguished by its occurrence only when the wind blows from certain directions; and, in studying phenomena of this sort, it should be remembered that a high, steep hill is capable of producing down-draughts in chimneys a mile or more away. Downward currents of this sort from neighboring hills or mountains are not easily cured. In the city of Geneva, which lies in a plain between two ranges of steep hills, down-draughts are so prevalent that it is usual to provide each flue with two outlets, turned in different directions, so that, if the air descends on one side of the flue, it may still have a chance to escape on the other; and, in extreme cases, a flue may be divided by a long strip of sheet iron hung in it, or two flues may be appropriated to the same fireplace, each division having its own outlet, so that the downward and upward current may be kept from mixing.

In most cases, however, the down-draughts due to obstructions to windward of a chimney may be prevented by covering the top of the flue or chimney with a semi-cylindrical cap of brick or metal, having its axis at right angles with the direction from which the downward current reaches it, so that the smoke can issue from the ends of the cap (Fig. 7). The chimney should, even with this precaution, be carried up as high as possible, both to increase the natural draught,

and to raise its outlet into a stratum where the downward current is less marked than it is nearer the ground. If, as occasionally happens, the flue is unnecessarily large, a similar effect can be obtained by contracting it toward the upper end, so as to give a tapering top to the chimney. The contraction of the flue concentrates the smoke, and prevents it from being mixed by diffusion with cold air as it approaches the outlet; and the tapering sides deflect upward the horizontal currents of wind which strike them, and even currents slightly descending, so that, instead of hindering the discharge of the smoke, they assist it (Fig. 8). The same form may be given to the top of a chimney without diminishing the size of the flues by cutting the bricks, and

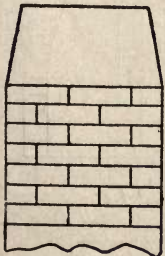

FIG. 8.

it is often advantageous to do so. A trumpet-shaped chimney-top, although picturesque and "English," is objectionable, often causing down-draughts by deflecting downward the currents which strike it.

Even if a fireplace flue is properly built, large enough, high enough, and not exposed to downward currents, the fireplace connected with it may still smoke

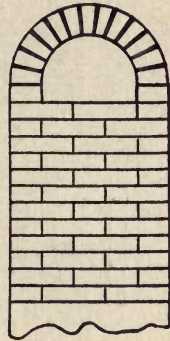

FIG. 7.

Fireplaces.

from faulty construction. The proper form is shown in plan in Figure 9, and in section in Figure 10. The sides are usually bevelled, for

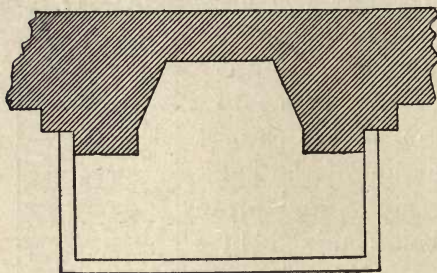

FIG. 9.

the sake of radiating more heat into the room, and a portion of the back is made to slope forward for the same purpose. The back should be

drawn forward to the "throat," which should be a mere slit not more than two inches wide; and just behind the throat should be a level shelf about six inches above the top of the fireplace opening. The narrowing of the throat, into which the flame and smoke are directed by the sloping back, prevents the entrance with them into the flue of cold air, which would chill the ascending gases and check the draught; and the level shelf behind the throat serves to repel occasional downward puffs

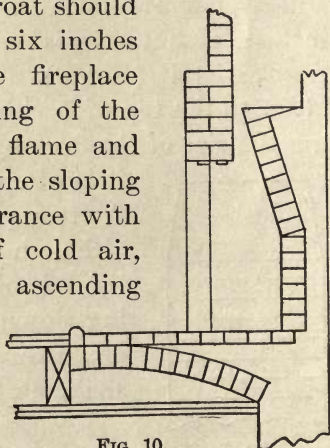

FIG. 10.

of air, and send them back up the chimney, instead of deflecting them out into the room, as a

sloping surface in that position would do. A fireplace damper serves in the same way to concentrate the smoke and gases, and, if properly made and placed, improves the draught. Dampers.

Besides being properly formed, a fireplace should not be too large or too high. If the opening is more than thirty inches high, whatever its width, smoke is likely to be blown out into the room by the movement of persons near it; and if short pieces of wood are burned in a wide fireplace, or if a portable grate for coal is set in a fireplace which it does not fill, the draught is greatly injured by the cold air which enters the vacant spaces at the sides of the burning fuel and mixes with the smoke. Trouble from this cause may be easily remedied by building little masses of brick at the sides of the fireplace, ten or twelve inches high, leaving between them just room for the grate, or for the wood ordinarily used; and, if the fireplace opening is too high, a copper or brass plate may be fastened over it.

A good fireplace is a precious possession in a house, and deserves to be cared for. In brick fireplaces the bricks at the back, where most exposed to the fire, crack, and slowly crumble away; but they can be replaced by new ones without much difficulty. Iron linings, if too thin, are apt to warp, but, if they have been well backed up with bricks and mortar, the warping may not affect the usefulness of the fireplace. Tile linings are, as a rule, meant only The care of fireplaces.

for show, and are incapable of resisting fire; but the soapstone linings once popular are quite durable.

Hearths.

In buildings with wooden beams the hearth, through the shrinkage of the floor-timbers around it, often cracks. If the hearth has been properly built on a brick trimmer arch, there is little danger from such cracks, as a spark falling through them is stopped by the brick arch beneath; but they are unsightly, and alarming to nervous people, and it is safest to fill them with cement, colored to match the hearth. If the latter is of brick, or of red tiles, the cement may be colored with Venetian red; and tiles of other colors, or marble, may be imitated in the same way.

Diagnosis.

In general, if a fireplace smokes, a diagnosis of the trouble may be made by observing, first, whether the smoking is intermittent or constant, and, if it is constant, whether it tends to diminish. If intermittent, it is probably caused by down-draughts, which may be treated as described above. If it is constant, but tends to diminish, it may be due to the dampness of the chimney. A flue which has been long unused, and is cold and damp, chills the current through it, checking the draught very materially until the masonry has become warm and dry; so that it should not be condemned until it has been well dried out by burning newspapers in it, or by keeping up the fire for a few days. If

this fails to produce improvement, and burning newspapers show that the chimney draught is good, the fault is probably in the fireplace. The chances are that this is too high. The surprising effect produced, in quickening a fire, by simply holding a wide board, or a folded newspaper, over the upper part of the fireplace opening, affords a striking lesson upon the importance of keeping such openings low; and a few experiments of this sort will soon show how much height the particular fireplace under examination will bear.

CHAPTER IV

STOVES AND FURNACES

ALLIED with fireplaces, but still more important in their relations to household life, are the stoves and furnaces with which every house is provided. All these consist essentially of an iron fire-box, under which is a grate, made with openings large enough to allow ashes to fall through, and air, for sustaining combustion, to pass in, but not large enough to allow the unburnt coal to escape. The smoke and flame from the fire-box, after describing a path more or less circuitous, are drawn off through an iron smoke-pipe into the chimney. In ordinary airtight heating stoves the smoke usually passes directly from the fire-box into the chimney; but, in order to increase its effect in warming the room, the iron pipe, instead of entering the chimney by the shortest path, is often carried up nearly to the ceiling, increasing by so much the heating surface. In stoves of this kind, control over the fire is obtained by means of a damper in the smoke-pipe, and two slides, one in the upper door of the stove, through which coal is put on the fire, and the other in the lower door, through which ashes are removed from the ash-

pit below the grate. To increase the combustion the upper slide is closed, and the lower one opened; while, to check the fire, the lower slide is closed, and the upper one opened. The reason why opening the lower slide intensifies the fire is that air is thereby admitted through the grate to the burning coal above it. In general, combustion is proportional to the amount of oxygen which reaches the fuel, as may be seen by blowing air among the logs of a wood fire; but the admission of air to the fire from under the grate serves an additional purpose, in that the heat from the quickened combustion of the lower layer of coal rises through the fresh coal above, causing it also to kindle. If, at the same time, the upper slide is kept closed, the air which ascends from underneath through the entire body of burning coal enters the chimney intensely heated; and, as the upward current in a chimney of given dimensions is proportional to the temperature of the smoke and heated gases in it, a strong draught is thereby established, which increases the amount of air drawn through the fire, and still further intensifies combustion. If, on the contrary, the upper slide is opened, cold air is drawn in above the fire, and, mixing with the hot smoke and gases from the fire, reduces their temperature just as they enter the chimney, and proportionally diminishes the draught in the chimney, and, in consequence, the rapidity with which air is drawn up from

below through the fire. The powerful effect of opening the upper slide in checking the fire may be understood by supposing the upper and lower slide to be of the same size, and both to be open at the same time. Assuming the current of air from the lower slide to lose half its velocity in finding its way among the coals and cinders in the burning mass, this hot current, before entering the chimney, would be mixed with twice its volume of cold air from the upper slide, and the excess of temperature over that of the external atmosphere, to which the draught is due, would be only one-third as great as that of the air derived from the lower slide alone. This amounts to cutting off two-thirds of the draught in the chimney, with a proportionate reduction in the intensity of the fire; and if, as is usual, the lower slide is closed, at the same time that the upper one is opened, the combustion is further reduced to an indefinite extent, as it is then maintained only by such air as may leak in through the joints of the door and slide to the space under the grate. With stoves of the simplest kind, the damper in the smoke-pipe may be wholly or partly closed, to reduce the volume of heated air passing into the chimney, and thereby again check the draught, and the combustion; but, on account of the danger of driving gas into the room if the smoke-pipe is completely obstructed, the damper is usually made with a notch, or hole, sufficient to carry off the smoke from a small fire.

By means of the upper and lower slides, and the damper in the smoke-pipe, very extensive control is obtained over a fire in a closed stove or furnace, and the same principle is applied to nearly all forms of heating apparatus. In open stoves, "Baltimore heaters," and open grates, for either hard or soft coal, the place of the upper slide is taken by a "blower," which is either entirely removable, or is attached, in the shape of a "curtain," which slides up and down. So long as the stove or grate is open, an immense quantity of cold air is drawn in from the room over the fire, which mixes with the smoke and gases before they enter the chimney, chilling them, and proportionately reducing the draught; but, by putting on the blower, or pulling down the curtain, the current of cold air drawn from the room above the fire is cut off, and all the air drawn into the chimney must come up from below, through the fire, thus quickening the combustion of the whole mass of fuel and greatly increasing the draught in the chimney. With ordinary grates, where there is no way of controlling the admission of air below the fire, the blower can only be kept on for a few minutes without danger of melting the grate; but most open stoves, and fireplace heaters of the Baltimore type, have a movable piece, containing a slide, which fits closely against the grate, and, by applying this, and using the slide for controlling the admission of air below, the blower can

be kept on, and the apparatus virtually converted into a close stove.

Base-
burners.

Two varieties of stoves should be mentioned before passing to more complicated apparatus; these being the base-burner and the jacketed stove. The base-burner differs from an ordinary stove simply in having an iron cylinder set in the upper portion, forming a reservoir of coal, which can be filled from the top. As the coal in the fire-box is consumed, a fresh supply descends by gravitation from the reservoir, so that frequent feeding is avoided; and, as the smoke-pipe is taken from the fire-box, outside the coal-cylinder, and this is provided with an iron cover, there is no danger that the coal in it will take fire.

Jacketed
stoves.

The jacketed stove, which is not so widely used as it should be, consists, substantially, of an ordinary stove, either open or closed, surrounded by an iron casing, at a little distance from the walls of the stove proper. The feeding and ash doors extend to the outer casing, and an ornamental open iron top usually covers the whole. In the cheaper forms, which are often used for heating country schoolhouses, the outer casing extends only to within three or four inches of the floor, so that air is drawn in below the edge of the casing, and rises through the space between the casing and the stove, becoming heated in its journey by contact with the stove on one side and the casing on the other, and finally

escapes through the openwork of the top. This circulation of air adds greatly to the heating power of the stove, and an extemporaneous casing of the sort may often be placed around an ordinary stove with advantage. A much more perfect arrangement, however, consists in supplying the space between the stove and the casing with fresh air from out of doors, which can be brought in through a pipe, warmed, and discharged into the room through the openwork top of the stove, giving admirable ventilation, which is still further improved when, as is the case with certain sorts, the stove itself can be used as an open stove, drawing in the warmed air, after it has made the circuit of the room, and thus maintaining a constant circulation. For a children's nursery, where an abundant supply of pure, warm air, and an open fire, not only for its cheerful and health-giving radiation, but for drying and warming clothing, and heating saucepans, are absolute essentials, no apparatus ever devised approaches these stoves.

CHAPTER V

THE KITCHEN STOVE

THE kitchen stove deserves at least a chapter to itself, for even a volume could hardly contain a description of the trials which housekeepers suffer in connection with it, and all the ingenious devices which have been invented to mitigate their troubles. It is, of course, in America that these devices are principally to be found, for the rest of the world is far behind our own country in the details of domestic convenience. Even now, many a lordly family in the most aristocratic part of London devours, as best it can, its victuals roasted in front of an open fire, and bathes itself in water warmed for the purpose over a gas flame; and the rest of the world is even behind England in the comforts to which the most modest American family is accustomed.

The kitchen stove, like other stoves, consists essentially of a fire-box, with a grate underneath it, and an outlet to the chimney; but, as it comprises also at least one oven, which must be heated, the smoke and hot gases from the fire-box, before they can escape into the chimney, are made, on occasion, to pass around the oven. Where there are two ovens, two smoke-pipes are

provided, each of which draws a portion of the hot gases around the oven to which it belongs; and the smoke-pipes finally unite, just before entering the chimney. In addition to heating the ovens, the smoke and gases in an American stove are obliged, before they can escape from their labors into the chimney, to supply hot water for the baths, sinks, and wash-trays; to maintain the hot-closets and plate-warmers at a suitable temperature; to dry the dish-towels; to broil, stew, fry, boil, and simmer all the family aliments requiring such treatment, and often, besides this, to boil the family wash and cremate the family garbage. To do all these things with one small fire requires that the heat should be well utilized, and the fire easily controlled; and a good American kitchen stove is a marvel of ingenuity. In fact, the ingenuity displayed in it is often rather beyond the comprehension of those who use it; and few stoves are so managed as to get from them the best results of which they are capable.

The fire-box proper of the ordinary American kitchen stove is made oblong, and rather deep, so as to hold a good body of coal; and the back, which is exposed to the force of the flame passing over the ovens, is protected by a fire-brick lining. The sides and front are protected in the same way, unless the stove is required to heat water for the baths and plumbing. In this case the front fire-brick, and often the side linings also, are replaced by a flattened box of cast iron, known as the

Water-front. water-front, in which all the water for the house is heated. Where the water-front is used, holes are provided in the side of the stove, through which pass the pipes connecting the water-front with the copper "bath-boiler," or, more strictly, reservoir, in which the water heated in the stove is stored for use. In most cases the water-front is a simple iron box, corrugated a little on the side next the fire, to strengthen it, and increase the heating surface; but the water-fronts of some stoves have an interior longitudinal diaphragm, which keeps the inflowing stream of cold water from mixing with the outflowing current of hot water, and materially improves the capacity of the stove for heating water; and, occasionally, a water-front is made of brass, at great expense, under the erroneous idea that water can be heated more rapidly in it than in one of iron. Very frequently, in modern stoves, the water-front does not reach the top of the fire-box, but leaves a space, two inches high or less, above it, through which, by means of a sliding door in the front of the stove, a broiler or toaster can be inserted above the fire without removing the stove covers, and a piece of meat thus broiled without allowing the smoke to escape into the room; and, occasionally, in large stoves, the water-front is put at the back of the fire-box, leaving the front of the fire, protected only by a grate, exposed, so that, by opening doors in the front of the stove, a chicken or duck, secured in a "Dutch oven" of

bright tin, to reflect the heat, can be roasted by direct radiation from the fire, instead of being shut up in the regular oven. This arrangement has, however, the disadvantage of keeping the front of the stove or range very hot; and, with modern stoves, in which air is allowed access to the oven while roasting or baking are going on, the difference in flavor of meat cooked in the oven or before the fire is mainly imaginary.

Under the fire-box is always a grate of some Grates sort, and in this feature is displayed a varied ingenuity which is frequently rather wasted. The best grates, for anthracite coal, are, perhaps, those of the type known as the Smythe, or "triangular-bar" grate, which is composed of revolving bars, set with flanges of a form nearly triangular, which interlock. The bars are furnished at the end with cog-wheels, gearing into each other, so that, when one is turned, the others turn with it, but in opposite directions; and, by means of a handle, fitting over the end of one of the bars, which projects for the purpose through the side of the stove, the different sections of the grate can be gently rocked, to shake out fine ashes, or turned entirely over; the triangular flanges, in this case, clutching the clinkers and cinders above them, and depositing them in the ash-pan below, before they resume their normal position. Although this operation is not an extremely complicated one, it is too much for the intelligence of the average Biddy, who can generally be seen, in the early

morning, digging out with a poker from the fire-box, with immense labor, and distracting noise, the cinders which, by a single turn of the grate-handle, might be transferred safely to the ashpan. With this form of grate the use of the poker at least does no harm, unless, as sometimes happens, it gets caught between the bars, and injudicious attempts are made to get it out again; but the same can hardly be said of another excellent form of grate, in which the turning of the shaking-handle moves up and down, in alternation, groups of small, detached grate-bars. When used intelligently, this is a very satisfactory grate, particularly with small or soft coal; but the process of digging out with a poker a fire-box furnished with it has the inconvenience that the poker not unfrequently brings up portions of the grate, mingled with the cinders, and repairs then become necessary.

There are many other forms of improved grate for kitchen stoves, which have nearly superseded the ancient plain or dumping grate, on account of their efficiency, in intelligent hands, in saving coal and labor. With a grate of the Smythe type, if care is taken to turn the bars over once, before any shaking or poking is done, nothing will be removed from the fire-box but the layer of clinkers and thoroughly calcined cinders which collects at the bottom of the fire; and, if the fine ashes are then removed by rocking the grate, without turning the bars over, no unburnt or

half-burnt coal need reach the ash-pan, and the dusty and disagreeable labor of sifting out the unburnt coal from the ashes can be dispensed with.

With any grate, care must be taken to remove the ashes from the pan before they accumulate too much. If the heap of ashes and cinders reaches the bottom of the grate, or even approaches very near it, so as to cut off the access of cool air to the under side, a brisk fire is likely to melt portions of the grate-bars, and ruin the grate; and, for a somewhat similar reason, the fine ashes which collect among the coals should be well shaken out before the draughts are opened to quicken the fire; otherwise the increased heat will melt together the loose particles of ashes and form clinkers, which not only adhere obstinately to the fire-brick linings, and to the bars of grates not specially designed for their easy removal, but, by filling up the interstices between the grate-bars, cut off the access of air, and materially check the fire.

Even if the grate is of a good pattern, and the fire is kept clear, the stove may not work well; and the trouble may be due to any one of several causes. The principal one of these is likely to be insufficient draught in the chimney, and this again may have various reasons. It is obvious that a considerable force is necessary to draw the smoke and hot gases from the fire-box through the long journey around the oven; and anything that in-

Bad
draught

terferes with the chimney draught at once affects the working of the stove. Very often, the chimney itself is at fault. The flue may be too small, or choked with fallen bricks, or exposed to down-draughts from neighboring roofs, or buildings, or trees, or hills; and troubles of this sort may be investigated and treated as described in the chapter on Chimneys and Fireplaces; but the draught of kitchen flues is frequently affected in other ways. Where the flue is of good size, not less than eight inches square, or, better, eight by twelve inches, and the chimney rises well above neighboring roofs, and shows no evidence, on being tested, of obstruction, the trouble, if the draught is defective, should be sought inside the house, and will, in most cases, prove to proceed from some leakage of cold air into the flue. It will be remembered that the admission of a very small amount of cold air, to mix with the hot gases in the flue, will chill them so as to reduce materially the draught of the chimney; and there are many ways in which cold air can get into a kitchen flue. A crack in the oven, for example, or imperfect fitting of the removable ovens used in many stoves, or a cracked top, or broken cover, or an open joint in the smoke-pipe, will admit quite enough cold air to affect the draught; and, where no defects of this kind are found, a diligent search will often discover that an ash-pit door, in the cellar or elsewhere, communicating directly or indirectly with the kitchen

flue, has been left open, or has been forced open by accumulation of rust; or the mason who built the chimney may, instead of keeping the kitchen flue entirely separate and isolated from top to bottom, have opened it at the lower end into a general ash-pit, through which it can draw air from other flues, or from the ash-dumps of fire-places. If no other reason can be found for the defective draught, something of this kind may be suspected, an investigation made by taking out a few bricks at the lower end of the flue, and the proper measures taken to shut it off from the ash-pit, if necessary.

Besides the troubles due to these defects or leakages, the draught of kitchen flues is very often injured by using the same flue for another stove, or broiler, or similar apparatus, or for ventilation. It is very common to see the lower end of a kitchen flue, in the basement, used for a laundry stove or a wash-boiler; or a laundry stove, or a broiler, set in the kitchen, beside the kitchen stove, and using the same flue; or a hood may often be seen, placed over the kitchen range, to collect and carry off the smell of cooking, with an outlet into the range-flue; or the same flue may be used for stoves in the chambers, or to receive the local vents, or other ventilation pipes, from bath-rooms or water-closets. In all these cases the draught will be more or less affected. If the kitchen flue is of ample size, and of good height, an air-tight stove

may usually be connected with it in the stories above without evil consequences, or a two-inch local vent from a water-closet may safely be carried into it, for the reason that either of these furnishes a comparatively small volume of cold air, and the air which they introduce enters the flue far above the kitchen fire, at a point where the smoke and hot gases from the latter have already received their first impetus, and have begun to cool of themselves, so that a slight addition of cold air produces less effect; but the connection of a large ventilation pipe, or of the smoke-pipe from an open stove, or any admission whatever of air into the flue in or below the kitchen, is very injurious, and, if separate flues cannot be utilized for such supplementary apparatus, they should be shut off entirely, or, if this is impracticable, they should be fitted with tight dampers, to be opened only when the extra apparatus is in use, and in a condition to contribute hot air, instead of cold, to the flue.

Even where no cold air can leak into the kitchen flue, the draught of the stove may be interfered with by obstructions in the stove itself. As the smoke and heated gases from the fire circulate around the oven, they carry with them, at times, fine ashes, which fill up the narrow spaces between the shell of the oven and the body of the stove, so as to choke the current. All stoves have provision for access to

these spaces for cleaning, and they should be well cleared out at proper intervals.

Where the draught of a kitchen stove is unsatisfactory, without being affected, apparently, by any of the conditions mentioned above, it may often be improved by carrying the iron smoke-pipe of the stove nearly to the top of the room, before connecting it with the chimney, instead of making the connection just above the stove. Although the long, vertical smoke-pipe contributes to the uncomfortable heating of the kitchen in warm weather, the opportunity which it gives to the hot gases to gain a certain upward impetus before entering the chimney often enables them to continue their journey properly the rest of the way.

Although the matter is, perhaps, more strictly connected with plumbing, it may be well to consider here the conditions under which a kitchen stove is most efficient in heating water by means of the water-front.

Heating
water.

The principle on which this heating is effected is that of circulation of the water from the bath-boiler through the water-front, or the coil of copper tubing which sometimes takes the place of the water-front, and back again; and this circulation should be as rapid as possible. As hot water rises, it is, or should be, evident that the more freely it can rise, the more rapidly it will do so; and, in order to obtain a rapid movement, not only should the brass pipes which

connect the couplings of the water-front with those on the boiler be large, but the upper pipe, which carries the water heated by the fire into the boiler, should rise somewhat sharply from the stove to the boiler. If it rises only slightly, or runs for a part of its course nearly level, as is often the case, the movement of the hot water through it will be sluggish; and, when the current is slow, the water is kept too long exposed to the fire, so that it boils or simmers, or sends large bubbles of steam into the bath-boiler, where they are suddenly condensed, with a thumping or hammering noise, by the colder water there. In either case a great deal of heat is uselessly absorbed in forming steam which, with a better circulation, would serve to heat the water quietly and rapidly, and to keep the upper part of the boiler well filled with a reserve of hot water.

The direction of the lower pipe between the boiler and the stove, which brings the cold water from the bottom of the boiler to the stove to be heated, is not so important as that of the upper pipe, but it is desirable to have it descend for at least a portion of the way from the lower coupling of the stove to the boiler. If, like the pipe from the upper coupling, the lower pipe ascends toward the boiler, or is laid level, some of the water heated in the water-front will try to escape through it, and will meet the incoming cold current on the way, checking the general circulation. Plumbers usually put a "sediment

cock" on the lowest point of the cold-water pipe between the boiler and the water-front, in order to drain the water from the whole hot-water system, in case of need; and it is desirable also on this account to have the pipe descend decidedly from the water-front, in order that the latter may be completely drained when necessary.

If the pipes between the water-front and the boiler pass behind the stove, as is frequently the case, or are carried for some distance on the kitchen wall, they will probably be laid for a part of their course nearly level, for the sake of what the plumber considers to be neatness, and the circulation will not only be slow in consequence, but the hot water, in its flow through a considerable length of exposed pipe, will lose some of its heat, particularly at night, when the kitchen is cold. If the hot-water supply is scanty from this cause, the upper pipe should be changed so as to rise directly from the stove coupling to the boiler. The lower pipe may be left level, or nearly so, if it would be troublesome to change it; and both pipes may with advantage be wrapped with asbestos paper, or some other non-conductor, to prevent loss of heat. The boiler itself, and such other hot-water pipes as can be reached, may be wrapped in the same way; and, as a last resort, a water-front with a diaphragm may sometimes be procured, or a coil of pipe substituted for the water-front. Any of these devices will to a

certain extent improve the hot-water supply, but it must be remembered that water cannot be heated without fire, and that the better the circulation, and the more abundant the hot-water supply, the more coal will be needed to provide for the other duties of the stove, and the stronger the draught must be, as a rapid circulation of water in the water-front, almost in contact with the coal, withdraws heat so fast as to chill the fire very materially.

Blowing up
of water-
fronts.

The water-front of the kitchen stove is often an object of apprehension to housekeepers, who imagine that it has a mysterious propensity to "blow up" on various pretexts, but more particularly when the water is drawn off from the boiler and a fire is made in the stove before the water is turned on again. Although it is not advisable to make a fire in a kitchen stove when the water-front is empty, on account of the probability that the iron shell of the water-front will be warped or cracked by the heat, or the couplings injured, it may be reassuring to know that there seems to be no authentic account of the "blowing up" of a water-front from the sudden admission of water to it when heated. That the water-front would be very likely to crack under such circumstances is true, and a great deal of steam would be generated, and probably find its way into the kitchen; but anything like a dangerous explosion is hardly to be feared. The contrary is the case, however, where a fire

is made in the kitchen stove when the pipes leading from the water-front are frozen; and many an unfortunate servant has been killed, and many a kitchen wrecked, by the terrific explosion which is sure to follow carelessness in this respect. If there is any reason to suppose that these pipes, or, in fact, any of the pipes of the hot-water system, are frozen, a very small fire should be made at first, just sufficient to thaw the water-front and the pipes, if they need it. If they are clear of ice, the warm water will in a very few minutes be felt flowing through the upper pipe from the stove to the boiler, and the fire may then be cautiously increased; but it is very dangerous to make a fire hot enough to generate steam in the water-front while the upper pipe leading from it remains cold, or until water flows freely from the hot-water faucets in the house.

CHAPTER VI

FURNACES

NEXT to the kitchen stove, the furnace presents the most troublesome problems to the housekeeper; and, in fact, most housekeepers abandon at once problems connected with the furnace, imagining that they can be dealt with only by experts. In reality, however, a furnace is a comparatively simple contrivance; and, except that it is bigger, is no more difficult to manage than a stove.

Very many ladies suppose that the hot-air registers in a furnace-heated house communicate with the fire-box, just as the smoke-pipe does, and fortify their opinion by observing that, when a new fire is kindled, smoke comes up the registers, and, when the furnace is shaken, fine ashes often make their appearance through the same openings. This impression of the construction of a furnace is very erroneous. Briefly described, every furnace is simply a large stove, surrounded by a casing, exactly like the jacketed stoves described in a preceding chapter, the fire being contained in the interior portion, while the air which is to be warmed and distributed through the house passes up through the space between

the inner portion, or furnace proper, and the galvanized iron or brick casing, but without communicating with the inner, or stove portion, in any way. It is true that smoke and fine ashes do often come up through the registers; but, unless the inner portion of the furnace is cracked or disjointed in some way, they do not pass from it into the warm-air pipes directly, but are drawn from the cellar, into which they escape when the furnace doors are opened, through the leaks which generally exist in the conduits supplying fresh air. Under the old-fashioned practice, by which the fresh-air supply to the furnace was taken entirely from the cellar, not only smoke and ashes, but coal-dust, mould-spores, and aromas of various descriptions were warmed up, and poured, all winter long, through the registers into the rooms. Now, however, nearly all furnaces are supplied with fresh air from out of doors through a "cold-air box," or conduit, of wood or galvanized iron, or, occasionally, of earthenware pipe, which leads from a cellar window, or other opening, either to the side of the furnace, or to a pit beneath it, so that the fresh air which comes through it can rise between the inner portion of the furnace and the casing to the registers above. If the cold-air conduit were always tight, no dust or smoke could get into it from the cellar, but it is usually furnished with a door, opening into the cellar, for cleaning, or for taking air from the cellar in extremely cold weather, when the power

Cold-air
box.

of the furnace is inadequate to the task of raising the fresh-air supply from the exterior temperature to that required for the rooms; and, as this door is never quite air-tight, smoke and fine dust are drawn through the crevices, and, entering there the current of fresh air, reach the registers. Many cold-air boxes, also, are made of wood, the sides consisting simply of matched boards; and the dry air of the cellar soon causes these boards to shrink, opening innumerable small crevices, through which dust, smoke, and gas can reach the rooms.

Although the principle of construction is the same for all hot-air furnaces, there is great variety in its application. The simplest furnace consists of an iron "fire-pot," usually, in this type, lined with fire-brick, to prevent the iron from cracking with the heat of the fire, and surmounted by a "drum," or cylinder with a closed top, usually of wrought iron. The fire-pot has a grate of some sort at the bottom, and under this is the ash-pit; and a door is fitted in the drum, above the fire-pot, for feeding the furnace with coal, and another in the ash-pit, under the grate, for removing ashes; while a galvanized iron smoke-pipe carries the smoke and heated gases from the upper part of the drum to the chimney. The fire-pot, drum, and ash-pit are enclosed by the casing, which is simply a galvanized iron cylinder, with a closed top, of a diameter some inches greater than that of the drum; and the feeding and ash doors are

extended so as to reach to the outside of the casing, the smoke-pipe, of course, passing through the latter on its way to the chimney. From the top of the casing proceed the tin pipes which lead the air admitted from the cold-air box, and warmed by its passage past the fire-pot and the drum, to the registers in the rooms. With a slide in the feeding-door and ash-door, to regulate the supply of air above and below the grate, and a damper in the smoke-pipe, to give still further control, the apparatus is, in all essentials, complete; and many such furnaces are sold, and give satisfaction under suitable circumstances.

A furnace of this kind cannot, however, be advantageously used to supply a large number of registers. It is a principle of the art of heating that air can be warmed only by actual contact with a heated surface; and, as the fire-pot and drum of such a furnace present a comparatively small surface, the air which can be made to come into actual contact with them on its passage between them and the casing is very limited in amount, and an attempt to enlarge the diameter of the casing, so as to allow more air to pass through it, simply results in admitting cold air to some of the registers, without increasing the amount of warm air. For this reason, all improved furnaces present devices, more or less successful, for enlarging the surface heated by the fire, so that more air can be brought in contact with the hot iron, and, in consequence, a greater

amount of warm air can be delivered through the registers, without admitting to them air which has escaped actual contact with the heating surfaces, and is therefore cold.

A simple method of increasing the surface heated by the fire is found in the "gill stoves," often used in England for heating churches, in which deep, vertical ribs are formed on the outside of the stove. As the heat from the fire extends very rapidly by conduction into these ribs, the surface available for warming the air which passes over the stove is multiplied by them many fold. As applied to furnaces, the principle of the gill stove is modified, the solid ribs of the stove being usually replaced by deep corrugations, into which the smoke and hot gases from the fire penetrate, increasing the effect; and, in a very good form of furnace, these vertical corrugations are themselves undulated, so that the air passing between them is thrown more effectually into contact with the heated iron.

In another type of furnace, the extension of the heating surface is obtained by means of a system of pipes, vertical, horizontal, circular, conical, or cylindrical, through which the smoke and heated gases are drawn by the draught of the chimney. The whole system is enclosed in a large casing, and it is presumed that the air passing through the casing will either come in contact with one or more of the pipes, or will be

mixed with air that has been in contact with them, so that the temperature of the air from the registers will be nearly uniform. In furnaces of this class, as the smoke from a freshly kindled fire could not be drawn by a cold chimney through all the convolutions of the system of pipes, a short cut is always provided, by which it can, at first, pass directly into the chimney; and later, when the chimney has become warm, and the draught is well established, the current can, by closing a damper, be made to pass through the rest of the system of pipes before it reaches the chimney. The short-cut, or "direct-draught" smoke-pipe is usually near the top of the furnace, and the damper in this is opened while a fresh fire is being kindled, or when the chimney has become cold and it is desirable to warm it to set up a proper draught. So long as the direct-draught damper is open, while the fire will burn briskly, little warm air will pass through the registers; but, by closing the direct draught, after the fire is well established, the smoke is sent through the "indirect draught," which usually issues from the furnace near the bottom, bringing all the heating surfaces into action, and greatly increasing the amount of warm air delivered through the registers.

Although the distinction between the two methods of increasing the amount of air heated by a furnace has a certain importance, most furnaces partake more or less of both types, those

with deep flanges having also some convolution of the smoke-pipe, by which a little extra heating surface can be gained, while those which depend upon a complication of smoke-flues usually have the fire-pot flanged, or corrugated, or covered with spikes, to increase its surface ; so that, in practice, nearly every furnace has its direct and indirect draught.

Check-draught.

In addition to these provisions, the control of a furnace fire is usually made very perfect by contriving, not only slides in the upper and lower doors, but a "check-draught," either in the "indirect-draught" pipe, or in the main smoke-pipe. This check-draught, in most cases, acts solely by admitting more or less cold air to the smoke-pipe or chimney-flue, but it is sometimes fitted with a damper, so that, when the current is checked by admitting cold air, the smoke-pipe is at the same time partially closed, producing a kind of double effect. In either case, the check-draught is made nicely adjustable, so that the entrance of cold air can be accurately controlled.

Automatic control.

Many devices have been introduced for making this control automatic, so that the furnace will open its own check-draught when the fire burns too briskly, and close it when the temperature falls. The cheaper inventions for this purpose, which act by the difference of expansion of two metal rods or tubes, set in the furnace casing, are, in most cases, of little use, their action being variable and uncertain ; but the more expensive

ones, which act by compressed air, or by electricity, are very efficient.

Most furnaces, in addition to their feeding and ash doors, and their direct and indirect smoke-pipes and check-draughts, show various complications, the purpose of which is not always very evident. Where the capacity of the heating portion of the furnace is comparatively small, as in those consisting merely of a drum over the fire-pot, the opening of the upper door will often chill the air above the fire so much as to check the draught, and, in consequence, the combustion of the coal, causing a quantity of poisonous carbonic oxide gas to be generated, which escapes through the door into the cellar, and is thence drawn into the crevices of the cold-air box, and sent through the registers into the rooms. In order to capture this gas as it issues from the door, and draw it off into the chimney, a narrow hood is often placed over the upper door of furnaces of this type, communicating with the smoke-pipe; and, in order that this may not act as a check-draught, a cover is fitted to it, and attached to the door, in such a way that when this is shut, the hood is closed, the opening of the door uncovering also the hood. As the leakage of cold air into the hood, even when it is closed by its cover, interferes appreciably with the draught of the furnace, it is doubtful whether it offers, on the whole, any advantage; and the same may be said of the openings which, in some furnaces, are

Additional
devices.

made from the ash-pit into the smoke-pipe, or into some internal flue, in order to carry off the cloud of fine ashes produced by shaking the grate. Although such openings are usually provided with a cover, which can be opened or shut from the outside, the cover is never perfectly tight, and, when clogged with ashes or cinders, as it is very apt to be, cannot be shut at all, so that the opening then acts as a powerful check-draught, interfering materially with the proper action of the furnace. In general, all openings into the smoke-pipes or flues of furnaces, except the direct and indirect draught connections, and the usual check-draught on the latter, are objectionable, interfering with the regularity and strength of the draught in the chimney, which affords the best safeguard against the escape of gas or fine ashes into the cellar.

Cleanouts.

There are, however, in every furnace certain openings, necessary for cleaning the heating surfaces, which vary in position, according to the design and construction of the furnace. These openings extend to the outside of the casing, and always have small iron doors, fitted as nearly airtight as possible ; and, unless they are forced open by rust, as is often the case, they do not materially affect the draught.

The cleanout doors are usually arranged at the back and sides of the furnace, and such extra doors as are found in front are generally intended either to facilitate the removal of clinkers, or to

allow a pan of water to be introduced into the air-chamber. The clinker-door, which is placed just over the ash-door, communicates by a long horizontal opening with the lower portion of the fire-pot, just above the grate; and its purpose is to allow the "clinkers," or lumps of melted ashes, which are apt to collect just above the grate, to be fished for, so to speak, with a light poker, with a hook at the end, provided for such contingencies, and pulled to the edge of the grate, where there is room for them to drop into the ash-pit. The water-door is higher up, and communicates only with the air-chamber, on a shelf in which is placed a cast-iron pan, fitting the shape of the fire-pot, and intended to be kept full of water, so that the evaporation from this may supply moisture to the warm air issuing from the registers. A few years ago, evaporation of this kind was thought to be essential to the health of persons living in houses heated by furnaces in winter, and the regular filling of the water-pan in the furnace, either by means of a dipper, or by an automatic arrangement, comprising an exterior pan, with water-supply and ball-cock, connected by a pipe with the inner pan, was a part of the ordinary household duties; but many physiologists now believe that a dry, warm air, if pure, and moderately heated, as is generally the case where it is supplied through modern furnaces, is more favorable to health in winter than an atmosphere which is warm and moist, and that people who

Evapora-
tion.

live in houses where no attempt is made to supply artificial moisture to the air in winter are less likely to take cold than those who have the pores of the skin, while they are in the house, kept open by an atmosphere intentionally moistened. Experience seems to have confirmed this view, and very few modern furnaces have any provision for evaporating water in the air-chamber. In the same way, the improved grates now in use remove clinkers much more quickly and effectually than is possible by the use of the hooked poker, and furnaces provided with such grates do not need a clinker-door, and are usually made without it.

A little knowledge of the principles of construction of a furnace will greatly facilitate its management, which is not often a matter of serious difficulty. As the control of the fire, proper economy of fuel, and the prevention of the escape of gas or ashes into the house, depend upon a good draught in the chimney, every precaution mentioned in connection with the flues of kitchen stoves should be observed with even greater care in regard to the furnace flue. A furnace flue is less likely than a kitchen flue to have additional stoves or fireplaces opening into it, but these are sometimes found, and it is more liable than a kitchen flue to have its draught spoiled by not being carried down, entirely separate from all other flues or ash-pits, to the very bottom; or by the unobserved opening of

ash-pit doors in the chimney, or cleanout doors in the furnace, by accident, or by rust; or by imperfect fitting of the smoke-pipe thimble into the brickwork of the chimney; or by any other accident or oversight through which cold air, even in small volume, is unintentionally admitted to the flue.

Supposing the flue to be tight, it must also be unobstructed. Most furnace flues are carried down to the cellar floor, so that a considerable space is left below the smoke-pipe connection, in which the fine ashes, carried into the chimney by the draught, can accumulate, but even this space will, in time, fill up, so that the ashes will rise above the mouth of the smoke-pipe, and choke the draught, unless they are from time to time removed through the iron door usually built in at the foot of the flue; and if, as is often the case in city houses, the space for ashes below the smoke-pipe connection is small, it is still more necessary to clear it out frequently.

Another common cause of sluggish or irregular draught in furnace flues is the improper arrangement of the smoke-pipe. This should be made as short and direct as possible, in order to avoid the cooling of the hot smoke and gases, and consequent loss of draught; and it should rise continuously from the furnace to the connection with the chimney. It is very common for the men who set furnaces, in order to give head-room for passing under the smoke-pipe, to make a por-

tion of it nearly or quite level, or even to give it in some places a slight pitch downward. While a pipe laid in this way will draw when there is a hot fire in the furnace, the strong upward current so created in the flue being sufficient to draw the smoke even downward for a short distance, the draught suddenly stops as soon as the fire is allowed to burn low, and the fire either goes out, or is revived with difficulty. This trouble is easily cured by changing the course of the smoke-pipe, so as to ascend continuously, without regard to the head-room underneath it. Then the moderately heated gases from a low fire, instead of trying in vain to dive down a depression in the smoke-pipe, or to creep along on a level, will at all times rise naturally to the chimney, and the fire will respond quickly to the closing of the check-draught, or the opening of the lower slide; while, the draught being at all times inward, even a cracked fire-pot, or an open joint in the furnace, will not allow gas to escape into the air-chamber.

If the chimney draught is good, the smoke-pipe properly laid, and all leaks of cold air into the flue stopped, the only further requisite for the proper combustion of the coal in the fire-pot is a suitable admission of air under the grate; and this may be interfered with in several ways. The worst of these is by the accumulation of ashes in the ash-pit; and, if these are allowed to reach the under side of the grate, not only will

the draught be checked, but, if an attempt is made to urge the fire, the grate itself is likely to be melted. Modern furnaces usually have small ash-pits, which must be cleared out at least once a day in cold weather, in order to prevent the dangerous accumulation which is likely to take place when the clearing can be postponed for a longer time, and is, in consequence, apt to be forgotten.

Where the ash-pit is clear, annoying but not dangerous obstructions are often due to the accumulation of cinders and clinkers above the grate. The old-fashioned furnaces were generally fitted with a "dumping-grate," consisting of a circular grating of cast iron, somewhat smaller than the lower opening of the fire-pot, and attached to a pivot in the centre, so that it could be turned over. The pivot projected through a slotted hole in the front of the furnace, so that the grate could either be moved laterally from side to side, by means of a suitable handle, or, by a different application of the handle, turned over. The lateral shaking served to sift out the fine ashes through the interstices of the grating, while the coarser cinders and clinkers, accompanied, usually, by some of the coal, fell over the edge of the grate into the ash-pit; and, when it was desired to clear out the furnace, or build a new fire, the grate could, with the same handle, be turned into a vertical position, allowing everything above it to drop into

the ash-pit. As only the clinkers and cinders at the edge of the grate were dislodged by the shaking, treatment with the hooked poker was generally necessary to get the lower part of the fire reasonably clear; and, even then, the middle portion of the grate could not be easily reached. Several devices have been introduced to meet this difficulty. In one furnace the grate is made in the shape of a basket, which can be turned, so as to bring any part of it to the front, and cleared of clinkers and cinders with a poker; and another form has a grate sloping downward from all sides to the centre, where there is a large hole, stopped by a plate, which can be dropped, so as to let the cinders and clinkers which have been shaken down to the hole fall out. The more recent furnaces are, however, generally equipped with some modification of the Smythe grate, similar to that applied to kitchen stoves, but on a larger scale, with the same revolving bars, with interlocking flanges, usually in two sets. These interlocking triangular flanges, when the bars are revolved, rise, clutch the cinders and clinkers over them, and, turning downward, drop them into the ash pit. In shaking a furnace provided with a grate of this kind, the first operation, after making sure that the ash-pit is cleared of the old ashes, should be to revolve each set of grate-bars once or twice, before any other shaking is done, following this by rocking the bars, to shake the

Shaking a
furnace.

fine ashes through. If the bars are rocked before turning them over, pieces of coal will be shaken down among the cinders, and will be dropped with them into the ash-pit, and lost; while, if the fire is left undisturbed until the bars are turned, the lower layer in the fire-pot will consist of nothing but cinders and ashes, or clinkers; and, after these are deposited in the ash-pit, by turning the bars over, the rocking, to shake out the fine ashes, can proceed without danger of shaking out coal. How far the removal of cinders by revolving the grate-bars should be carried depends on the coal used, and the previous condition of the fire; but, when a bright light is seen in the ash-pit, the fire may be considered, with this form of grate, to be quite clear.

With the older forms of grate, the ash-pit may be brightly illuminated from the edges of the grate, while the middle is still occupied by a huge mass of melted ashes and cinders, which can only be removed by laborious extraction through the door; and, as these inert masses diminish materially the efficiency of the fire, it is desirable to prevent them from forming, which can generally be done by keeping the fine ashes well shaken out, and avoiding, as far as possible, opening the lower door of the furnace. There is a great difference in coal as to disposition to form clinkers, but an infallible way to produce them, with any coal, is to send an ignorant servant to "start up the fire" in the morning.

Clinkers.

"Starting up the fire."

Unless careful instructions are given, this object is generally accomplished by closing the check-draught, if it has been open, and opening the lower door of the furnace, without disturbing the ashes which have been accumulating in the fire-pot during the night. The flood of air admitted under the grate effectually "starts up" the fire, which, with a reasonably good chimney draught, soon becomes hot enough to melt the ashes into solid masses; and, by the time the housekeeper arrives, and provides for mitigating the furious combustion, the mischief is done.

In place of these violent proceedings, which are very wasteful of coal, as well as destructive of the furnace, all regulation of furnaces should be carried out with caution. A good automatic regulator will soon save its cost in a large house; but, where this cannot be employed, much may be done by putting on a large quantity of fresh coal at night, and leaving it with a moderate draught, so that, by morning, the mass will be well ignited, without burning furiously, and without needing to be inordinately "started up."

Manage-
ment of a
furnace.

In general, furnaces, when used with anthracite coal, work most economically and efficiently by keeping the fire-pot, in cold weather, filled as high as possible with coal, and allowing only a moderate combustion. As the air which passes through the air-chamber is warmed only by actual contact with the heated walls of the furnace and smoke-flues, it is found that a large

extent of surface, at a moderate temperature, is much more effective, with the same expenditure of fuel, than a narrow zone, intensely heated by a small, but furious fire; and the latter is far more likely to crack the fire-pot, or cause other mischief, than a larger but more moderate fire. At the same time, if a large body of coal is maintained in the fire-pot, care must be taken not to open the lower door, and forget to close it again, as a large body of coal, burning furiously, is, naturally, more difficult to check than a small one.

Many hot-air furnaces have a "hot-water attachment," or "combination," consisting of a cast-iron receptacle, of form varying according to the furnace used, or, sometimes, of a coil of pipe, suspended in the drum of the furnace, which is kept full of water, and connects, by flow and return pipes, with hot-water radiators in certain rooms. These attachments are valuable for carrying heat to rooms which cannot well be supplied with hot air from the furnace, and require little care, except to keep the radiators from freezing, and not to build a fire in the furnace unless the water attachment is full of water, for fear of burning it out. They add to the quantity of coal consumed, particularly if the pipes leading to the radiators are exposed to cold air; and it is well to remember that where the hot-water heater is placed at the very top of the drum, as is sometimes the case, the coal

Hot-water
attach-
ments.

should be piled well up, so as to get the fire as near as possible to the water, in order to secure satisfactory results. If well managed, such hot-water attachments make it practicable to heat with the furnace rooms so far away from it that hot air could not be made to flow into them, or so situated that a tin hot-air pipe could not be carried to them without disfiguring some other room.

Hot-air
pipes and
registers.

The tin pipes used for conveying the hot air from the air-chamber of a furnace to the rooms to be heated, and the registers through which it is delivered, are important portions of the heating system. Much heat is lost during the passage of the air through the pipes, particularly if these are long, or pass through cold rooms, or near outside doors; and they should, in these places, as well as where they are carried up in partitions, either be made double, consisting of two pipes, with a quarter-inch or half-inch air-space between them, or wrapped with non-conducting and non-inflammable asbestos paper; or the two systems may be united, making the pipes double, as well as covering them with asbestos, where the best results are desired. Where two pipes run side by side, it is advantageous to unite them in the same wrapping of asbestos, so that one may warm the other. With all the care that can be taken, it rarely happens that all the rooms in a furnace-heated house can be warmed equally under all conditions of wind. The force

which sends hot air through a pipe, being, usually, simply the difference in weight between the warm air in the pipe and an equal bulk of cold air, is so slight that a very small circumstance may affect it; and, in a high wind, the natural tendency of the air in the house toward the lee side usually carries with it the warm currents through the registers, which flow freely into the rooms on the side of the house away from the wind, but can hardly be felt in the rooms on the windward side. In order to counteract, to a certain extent, this effect, it is usual to direct the opening of the cold-air box, by which fresh air is taken from the outside to supply the air-chamber of the furnace, toward the north or west, so that the coldest winds may blow into it, and increase in that way the force of the current through all the registers; and a furnace is occasionally seen fitted with two fresh-air inlets, one on the east side of the house, and the other on the north or west side, so that advantage may be taken, by closing the inlet on the lee side, and opening that on the windward side, of any cold wind.

With a reasonably efficient furnace, there is little danger that all the air which will blow in through an ordinary cold-air box cannot be heated after the fire is properly started. Until then, as the circulation of a strong current of cold air through the air-chamber chills and checks a feeble fire, it is often advisable to shut off a

Air-supply.

part of the air-supply. The full supply should, however, be restored as soon as the fire has gained strength enough to be capable of warming it. If this is not done, either air will be drawn from the cellar, through crevices in the cold-air box, or some of the registers will be deprived of heat, as very few cold-air boxes are designed of sufficient size to supply all the registers dependent upon them without the aid of the wind blowing into them, or of air from the cellar. The proper sectional area of the cold-air box is the sum of the sectional areas of all the hot-air pipes, less one-sixth, this fraction representing the expansion of the cold air by heating. Where the capacity of the cold-air box is less than this, the air must be economized, at least in calm weather, by shutting off a part of the supply to some of the registers, by partially closing the dampers in the pipes which convey warm air to them. If this is not done, the registers most favorably situated will draw air down through those less so, to make up for the deficiency of fresh air from the outside. The dampers for this purpose, as well as for equalizing the distribution among the various rooms, are, or should be, placed in the hot-air pipes, near the furnace; and, where the heat is to be entirely shut off from rooms which are not occupied, the same dampers should be used for the purpose, so that heat may not be wasted in the pipes leading to the unoccupied rooms.

Of the troubles to which furnace-heated houses are subject, the most common is the unequal heating of the rooms. To a certain extent this is inevitable, a perfectly uniform distribution of the warm air being impracticable; but much may be done to equalize the currents, or, at least, the heat of the rooms which they supply. In general, the higher a pipe ascends, the stronger will be the current through it, for the reason that the difference of weight between the column of warm air in it, and a column of equal height of the exterior air, is correspondingly greater. This is the reason why furnace-pipes to upper rooms are always made smaller than those to first-story rooms, the rapidity of the flow of air through them making up for its diminished volume; and advantage can often be taken of this principle to increase materially the delivery of warm air into a room with a register in the floor by setting up over the register a pasteboard cylinder, or rectangular box, according to the shape of the register, open at both ends, and four or five feet high. This simple device, when used in first-story rooms, may more than double the height of the warm column, and, under some circumstances, greatly improve the heating of the room.

Unequal
heating.

For the same reason, that a high column of warm air will overpower a low one, if the supply is not sufficient for both, it is very common, where the cold-air box of the furnace is of insufficient capacity, to find one or more registers in

Cold
register.

the house, usually in the first story, and most frequently, perhaps, in the entrance hall or staircase hall, which deliver little or no warm air; and, by testing them with smoke, a downward current may often be detected in them. This is so much a matter of course in most houses that it attracts little attention; but it is by no means necessary, and if an adequate supply of fresh air is given to the furnace, and the dampers in the hot-air pipes are adjusted, so as to cut off a part of the flow into the rooms which have more than their share of warm air, and throw it into those which have less than their share, all the registers can, with a furnace of sufficient capacity, be made to deliver warm air.

Hall registers.

The reason why hall registers are more apt to fail in doing their duty than others in the same story is that the cold currents entering around or through the door, or descending a staircase, press upon the surface of the register, slightly, but sufficiently to counteract the very feeble ascending force of the current in a first-story register. In consequence of this, a hall register should never be placed under the well of a staircase, but under the staircase itself, or in some other position where it will be sheltered from the descending current; nor should it be placed where the wind from the door will blow directly upon it. In cases where hall registers have already been badly placed in this respect, their efficiency may often be improved by putting a table, or other piece of

furniture, over them, so as to shelter them from cold currents.

The current from a register may, however, be greatly affected by other causes than that of a want of balance between it and other currents. The most serious of these is, perhaps, the exposure of the pipe supplying it to cold currents of air, which, added to the friction in a long pipe, particularly in a pipe which has not a decided and continuous ascent from the furnace, will often completely annihilate the flow. Much may be done in such cases by wrappings of asbestos paper, in several layers, to protect the pipe from the cold, using in preference the corrugated paper, which is a much better non-conductor than the plain paper; and it is often possible, by changing the position of a register, to shorten very materially a long pipe, without any inconvenience whatever, and to the great improvement of its heating power. In general, the registers in rooms at a distance from the furnace should be in the side or corner nearest the furnace. The rule for steam or hot-water radiators, that they should be placed under the windows, or in the coldest part of the room, is totally inapplicable to hot-air registers, the efficiency of which mainly depends on the shortness and directness of their communication with the furnace. Vertical pipes, especially those carried up in partitions, or behind furrings, are often exposed to cold air, and can have their working improved by covering them, or, if that is

impracticable, by admitting warm air from a kitchen, or some other warm room, to the space in which they run ; or, in extreme cases, a new pipe may be carried up inside the old one, or in a different place.

If all these precautions fail to improve the warming of a room, the fault may be in the furnace, which is very likely to be incapable of heating a sufficient quantity of air to supply all the rooms. Many furnaces, particularly those of the simplest wrought-iron type, in order to throw the air passing through their air-chambers against the comparatively limited heating surface of the furnace, have a flat ring fastened to the inside of the casing, leaving a narrow annular space, sometimes not more than two inches wide, between this ring and the drum of the furnace, through which must pass all the air to supply all the registers in the house. With all reasonable allowance for the increased rapidity of the currents next to the hot surface, it is obvious that the quantity of air which could pass through so small an opening would be very inadequate to supply any considerable number of registers ; yet it is not uncommon to see houses, with furnaces of this sort, in which the register area is far beyond the capacity of the furnace to supply. Where there is reason to suppose that a furnace is overtaxed in this way, something may be done to improve its working by nearly closing the dampers in the hot-air pipes, so that each room

can get a small share of the hot air. Then, by driving the furnace, the air may be made so hot that the small quantity delivered to each room, mixed with the other air in the room, will give a tolerable temperature to the whole; but the only remedy which is really satisfactory is to put in a furnace of a different kind, with sufficient heating surface to warm the amount of air required for all the pipes.

It may be observed that warm air, either from a furnace or an indirect steam or hot-water apparatus, will not enter freely a room which has no outlet, either in the shape of a fireplace, or an open stove, or a ventilating register, or even a "stove hole" into a flue; and the better the house is built, and the more tightly the windows fit, the more difficult it will be to heat such a room with a register. In cases of this kind, an escape for the air should be contrived by an opening into a flue, or even by means of a transom sash, or a hole into a hall or another room, making the opening as high above the floor as practicable. It often happens that nothing more is needed to enable a furnace to keep a room comfortably warm which could not previously be heated.

CHAPTER VII

STEAM AND HOT-WATER HEATING

IN most large houses, and in many small ones, heating is effected by means of steam or hot water, on account of the ease with which heat is in this way transmitted to places which could not be reached with hot air from a central furnace. Of both steam and hot-water heating there are two varieties, the direct system, by which a radiator, through which the hot water or steam circulates, is placed in the room to be warmed, and the indirect system, by which the radiators are placed in the basement, and serve to heat a current of fresh air, which is brought in from the outside, and, after warming, is conducted to the room to be heated. The obvious advantage of the latter method is that the rooms are not only warmed, but supplied with fresh air, while, under the direct system, no fresh air is introduced, the radiators serving simply to heat the air already in the room. In practice, the two systems are frequently used together, the main rooms, for example, in a house being warmed by hot air from indirect radiators in the basement, while the halls, and often the chambers, are heated by direct radiation from

Direct
system

Indirect
system.

radiators standing in them. Occasionally, also, a dwelling-house is heated by steam or hot water on the so-called "direct-indirect" system, where the radiators standing in the rooms are supplied with fresh air through small openings in the wall behind them, or from pipes brought to them through the floors; so that the occupants of the room can have the direct heat of the radiator, with a certain amount of fresh, warm air in addition.

Direct-indirect system

Each of the two principal systems has its advantages and disadvantages, which are shared proportionally by the mixed systems. A complete indirect system is more expensive in first cost, and involves about twice as great an expense for fuel, as a direct system which will do the same amount of heating; but the constant supply of fresh air which it affords is a great advantage, and an indirect system is more compact, and less likely to be injured by freezing, or to do injury by leaking valves, than a direct system. On the other hand, a direct system, besides the economy which it offers in cost of installation and maintenance, is more easily managed, as the boiler is smaller, and there are no air conduits to look after.

Relative advantages

Most boilers for house heating, both for steam and hot water, are made of cast iron, in sections, so that, by varying the number of sections, the power of the boiler can be adapted to the circumstances of the case. Some of the larger

Boilers.

boilers are enclosed in a brick setting, but the majority of those used for house heating are either covered with asbestos or magnesia, to prevent loss of heat, or are left bare. In the early days of cast-iron sectional boilers, when used for steam, a section, owing to imperfect circulation of the water, would occasionally burst; but this accident, owing to the small proportion which a single section bore to the whole boiler, rarely had any worse consequence than the upsetting of the household economy while repairs were being made. Now, however, the designing of such boilers is better understood, and an accident of the sort is of rare occurrence.

Hot-water
heating.

Hot-water heating, for which the same boilers are used, dispensing with the safety-valve, and water and pressure gauges, and some other accessories, has certain advantages, for dwelling-houses, over steam heating. As water boils, under normal atmospheric pressure, only at a temperature of 212° , no steam can be formed, or forced into the radiators, at any lower temperature than this, except by means of air-pumps, condensers, or other devices, which are too complicated and costly for use in ordinary houses; and, with the light pressures used in house apparatus, the steam can be raised very little above this temperature, as a slight increase in the temperature increases the pressure to the point at which the safety-valve opens. The tem-

perature of a steam radiator can, therefore, under ordinary circumstances, be varied only within narrow limits, and if it is powerful enough to heat a given room satisfactorily on a cold day in winter, it will be far too powerful for the same room in mild weather; yet nothing can be done to mitigate its heat except to shut off steam altogether, which will leave the room cold, or to open the windows, wasting the heat, and endangering sensitive people in the room. This inconvenience is particularly felt in houses heated by direct steam at night, when, as the temperature of the radiators cannot be materially varied, it is necessary either to keep up steam all night, making the rooms as warm at night as in the daytime, or let the steam go down to a point below 212° , when the radiators at once become perfectly cold. With an indirect, or a direct-indirect system, something can be done to modify the temperature by opening or closing the registers, and thus varying the air-supply; and direct radiators are sometimes made double, so that one-half only may be used at night; but these devices increase the cost, and, if steam is to circulate at all, a large fire must be kept up through the night.

With hot water, on the contrary, the heat of the radiators can be varied to almost any extent, as the water simply flows through them, bringing with it whatever temperature may have been imparted to it, from the freezing-point to the

Hot-water
heating.

boiling-point. It is, therefore, not necessary to keep up a bright fire through the night, a low fire being sufficient to keep the radiators at whatever moderate temperature may be desirable. For this reason, hot-water heating by direct radiation is very popular among the owners of small houses, as the heat is capable of perfect regulation, while the boiler is small, durable, and easily managed, and the cost of fuel is less than for any other system of heating equally efficient.

Indirect
hot-water
heating.

Although direct hot-water heating, owing, mainly, to its better regulation, but also, perhaps, in some degree, to the lower temperature of the heating surfaces, is less oppressive than direct steam heating, neither system affords any ventilation; and, to secure a supply of fresh air in connection with the special advantages of a hot-water system, indirect radiators, similar to those used for steam, must be placed in the cellar, and the fresh-air current passed through them. As the temperature of the hot-water radiators, under the open-tank system generally used in this country, is considerably lower than that of a steam radiator, their size must be proportionately increased, in order to obtain sufficient power for the coldest weather; and an indirect hot-water heating system is on this account both bulky and expensive, although, where the necessary space and money can be afforded, it gives admirable results, with a comparatively small

expenditure of fuel. The intermediate system, known as direct-indirect, where the radiators standing in the rooms have special air-supply, although common with steam, is very rarely applied to hot-water heating, probably on account of the danger of freezing a hot-water radiator in which the circulation happened to be cut off or obstructed.

The difficulties encountered in the management of steam or hot-water heating apparatus, either direct or indirect, are usually due either to insufficient heating surface, insufficient boiler power, or imperfect circulation. Where heating work is done by contract, the contractors, who have usually secured the work by putting in the lowest bid, in competition with other contractors, are naturally tempted to furnish the smallest radiators and pipes, and the cheapest and smallest boiler, that they think the owner can be prevailed upon to accept. It seldom happens, under such circumstances, that the house is comfortably warmed in the coldest weather; and, if the owner obstinately declines to accept argument in place of heat, the contractor, if, as should always be the case, he has given a written guarantee to heat a certain list of rooms simultaneously to 70° when the thermometer outside stands at zero, without overtaxing the boiler, will generally begin by taking out the radiators in the coldest rooms, and substituting larger ones. If the boiler is really large enough, this process, if carried suffi-

Difficulties
in manage-
ment.

ciently far, and if the pipes are of the proper size, and well arranged, will remove the difficulty; but if the boiler is too small, so that, with steam, it is necessary to maintain more than the usual standard, for house boilers, of ten pounds' pressure, to furnish the required heat, this also should be rejected, and a larger one put in.

Where a large house is to be heated, it is advisable for the owner, or some expert for him, to calculate, by means of the simple rules given in the text-books, the sizes of the radiators which will be needed for rooms of the given dimensions, considering also the window surface and the exposure, and deduce from these the necessary size of the pipes, and the required heating and grate surface of the boiler, and to make the contract accordingly. As all these conditions must be fulfilled before the building can be properly heated, it is a saving of time and money to see that they are complied with at the outset.

Even where the boiler, pipes, and radiators are large enough, some of the rooms may fail to heat, owing to imperfect circulation in the pipes. This may occur either with steam or hot water heating, but it is more easily remedied with the latter. In general, the ideal hot-water heating system may be said to consist of a vertical loop, with the boiler at the bottom, the hot water flowing out of the top of the boiler into the ascending portion of the loop, and, as it cools, returning by the descending portion of the loop

Imperfect
circulation.

into the bottom of the boiler, where it is again heated, and again rises, to go through the same course. In practice, however, this simple plan must be modified in various ways. In order to heat several rooms on the same story, it is necessary to use branch pipes, running nearly horizontally, to supply some of the radiators, at a distance from the main ascending and descending pipes. If these branch pipes, both for flow and return, can be kept either perfectly horizontal, or inclined in parallel lines, the flow-pipe continuously ascending to the radiator which it supplies, while the return-pipe continuously descends, the circulation will still be good; but a dip in either pipe below the horizontal, or a curve above it, will, unless special precautions are taken, stop the flow, for the reason that, in a downward dip, cold water, being heavier than hot water, accumulates, interposing a barrier to the current, while an upward bend is soon filled with air from the bubbles carried along in the water, and, as the current has not force enough to push the air out of its path, the circulation is stopped in this way as effectually as in the other. In fact, an "air-bound" pipe is more effectually stopped than one with a dip in it; for, by carrying up a loop of pipe, in such a way that the water, before it reaches the dip, ascends as high above the general line of the pipe as the dip is below it, or, if possible, a little higher, the resistance of the cold water in the dip will be

overcome, and circulation will go on without interruption, while an air-bubble confined at the top of an upward bend can only be got rid of, and the flow restored, by letting the air escape through a valve or otherwise, which is not always an easy matter.

In practice, hot-water systems are usually so arranged that the water rises from the boiler almost immediately to an "expansion-tank" at the top of the house, the pipes descending thence, and supplying the radiators on the way, so that the force gained by the elevation of the expansion-tank above the general heating system is available to lift the water out of any dips that may be necessary to carry the pipes past doors or under floors; but this is not always the case, the radiators being sometimes fed from the upward current. In either case, the whole system, including any upward bends, if these are used, should be so arranged that air-bubbles in any pipe will rise to the expansion-tank and escape.

Unfortunately, hot-water systems are not always arranged as they should be, and both pipes and radiators often contain "traps" for air-bubbles, unprovided with means of escape for the air to the expansion-tank, so that, in place of such means, air-valves must be used, either opened by hand, or automatically operated, by means of a little float inside them, to prevent the circulation from being stopped, and the radiators or pipes from becoming cold.

Where a hot-water radiator will not heat, there is reason to suspect a stoppage of the flow from one of these two causes; and the course of the pipes should be examined, to ascertain whether a dip downward, or a bend upward, is responsible for the trouble. If the former is discovered, the pipes should be straightened; or, if that is impracticable, a rising loop may be made above the dip, remembering to provide an escape for air-bubbles gathering at the top of the loop; or, in some cases, a pipe may be carried down from the bottom of the dip to a return-pipe. If, on the contrary, an upward bend is found, without provision for the escape of air, such escape should be provided, either by drilling the pipe, and putting in an automatic air-valve, or by connecting the top of the bend with a pipe communicating with the expansion-tank. If neither of these is found practicable, relief may sometimes be obtained by carrying either the flow or return pipe from the ailing radiator, or both, directly to the boiler, instead of taking them as branches from a main vertical pipe. In some small houses every radiator has its own separate flow and return pipe from the boiler, the upper ends of the loops thus formed being connected with the expansion-tank. Although this arrangement involves a greater length of pipe than branching from a main supply and return, the pipes used are smaller, and, therefore, much cheaper, and a good deal of complication

is avoided, while the circulation in the radiators is always good.

Circulation in a steam system is as liable to interruption as that in a hot-water system, but in a different way. The pressure under which the steam is driven through the pipes prevents stoppage by the collection of water in downward dips, or of air in moderate upward bends; but radiators, in which the steam enters at the bottom, and, after a devious course through the radiator, escapes again at the bottom, are very apt to fill with air, so that steam cannot be forced into them, and they are usually fitted with air-valves, automatic or otherwise, to allow the air to escape. Many steam radiators will not heat at all until the air-valve is opened; and, as a sudden rush of steam and water usually follows the expulsion of the air, such valves, unless automatic, must be carefully watched, when opened, or the room may be flooded with water, or filled with steam, to the ruin of the furniture.

In a large system of steam heating every radiator has two pipes, one for supplying it with steam, and the other for draining off the water which forms in it from the condensation of the steam, and returning it to the boiler; the return-pipe being usually a size smaller than the steam-pipe. Most house systems are, however, for the sake of economy, arranged for what the steam-fitters call a "one-pipe job," the steam entering

the radiator through the same pipe which carries the condensed water away. Where the pipes in a one-pipe system are large enough, they are not likely to give trouble; but, where they are of insufficient size, the steam rising through them to the radiators has not room enough to pass amicably by the condensed water flowing in the opposite direction, on its way down to the boiler, and pushes it back in part, at the same time that it squeezes past it in what space may be left. The water thus held back by the current of steam accumulates, until there is enough of it to fill the bore of the pipe completely, cutting off the passage of steam beside it. The steam then, being unable to pass by, pushes the plug of condensed water violently before it, until it is dashed against the inside of a radiator, or a turn in the pipe, producing the "hammering" noise so common in steam-heating systems, and, with high-pressure steam, sometimes breaking the radiators or fittings.

Even with a two-pipe system, where the steam enters the radiators by a different pipe from that which carries off the condensed water, hammering often occurs in the steam-pipes, from the collision of the steam with water condensed in the steam-pipes themselves. It is obvious that, wherever the steam is exposed to cooling, water will be condensed from it, whether the process takes place in a supply-pipe or in a radiator; and, if the supply-pipes are long, particu-

larly if they have also branches, the amount of water condensed in them, and flowing down, in opposition to the current of steam, may easily be sufficient, if pressed back by the steam, to fill the bore of the pipe.

Remedy for
hammering.

The remedy for hammering in steam-pipes, whatever may be its source, is simple in theory, but is sometimes expensive. It is obvious that, if the steam and the condensed water can be made always to move in the same direction in the pipes, there will be no collisions, and no hammering; and all steam-heating systems should be arranged as far as possible on that principle. In Figure 11, for exam-

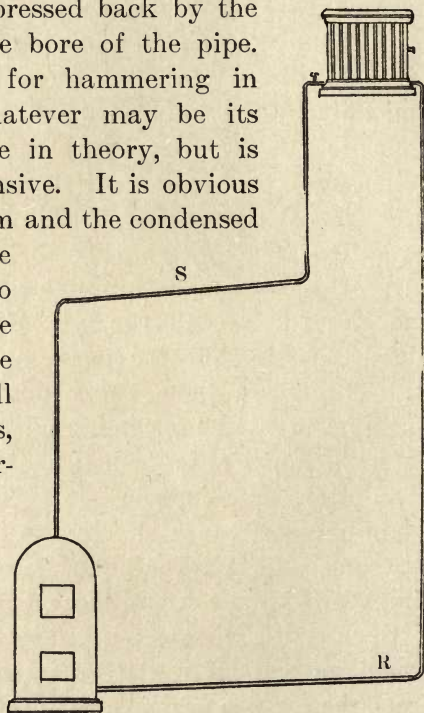

FIG. 11.

ple, it is evident that the steam-pipe S, supplying the radiators above, will, even if the radiators have separate returns, and much more if they do not, be at all times partially filled with water condensed from the steam passing through it, and flowing back to the boiler; and on very cold

days, when condensation is rapid, or early in the morning, when the steam is first turned into cold pipes, there will be a large amount of water running back, in a direction contrary to that of the steam current, and collisions and hammering are at such times inevitable. By arranging the same pipe as shown in Figure 12, and adding the "relief" or "drip" pipe shown at D, the condensed water in the horizontal portion of the pipe will flow in the same direction as the steam toward the point P, where it is immediately drained off through the pipe D into the main return-pipe R. A little water will still condense

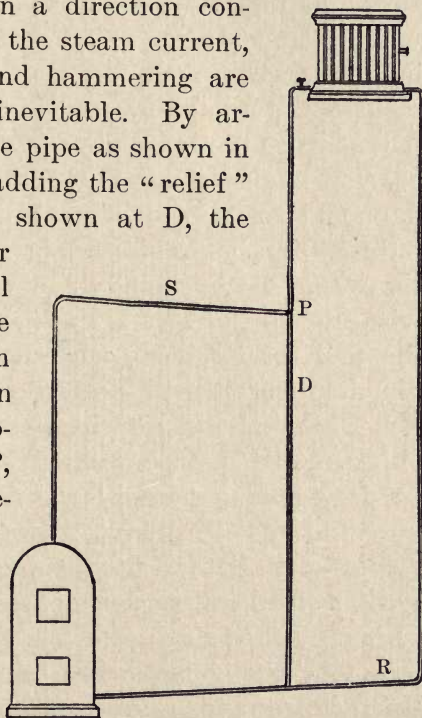

FIG. 12.

in the vertical steam-pipe between P and the radiator, and will flow down in opposition to the current of steam, but it is too small in amount to give trouble, and is drained off as soon as it reaches the point P, by the drip-pipe D.

Where a steam-heating system has been laid out with insufficient care, so that it gives annoyance by hammering, relief-pipes can often be added in this way, so as to cure the trouble, without any great expense; and, where this is impracticable, something may often be gained by covering the long, vertical steam-pipes with felt, so as to diminish the condensation in them.

In managing steam radiators with two pipes, it should be remembered that the smaller, or return-pipe, communicates, in most cases, with the water of the boiler; and if it is left open, when the steam-valve is shut, the vacuum left in the radiator by the condensation of the steam remaining in it will draw up water from the boiler into the radiator, nearly or quite filling it. With small house-heating boilers the water may be drawn dangerously low by being sucked up into the radiators in this way, and the two valves of radiators fitted up on the two-pipe system should always be opened or closed together. In a single-pipe system the radiators have but one valve, which shuts off or opens both steam and return at once. Where the radiators to be cared for are those of an indirect steam-heating system, it is still more necessary to remember to shut off the steam and return together, as a radiator which has been allowed to fill with water through neglect to close the return is likely to freeze and burst where exposed to the cold air which passes

Freezing.

through the fresh-air conduits of an indirect system. The radiators of a direct-indirect system are also liable to freezing in the same way, if allowed to fill from an open return. In any case, if a return-valve has been left open when the steam-valve is closed, so as to allow the radiator to fill, the water may be easily expelled by opening the steam-valve. The pressure of the steam soon forces out the water through the open return-valve, and when the gurgling noise incident to this process has ceased, and the radiator is warm in all portions, both valves may be closed.

As the radiators of a hot-water system cannot be emptied separately of water, they are always in some danger of freezing in cold weather; but a small fire in the boiler will be sufficient to keep the water in them warm, where a steam radiator, owing to the lack of pressure enough to force steam into it, would be cold, and, if full of water, would freeze. As the freezing of a hot-water radiator is a serious matter, care should be taken, in very cold weather, to see that none of the radiators are shut off, by closing the valve, which, in the case of a hot-water system, leaves the radiator full of water. Any pipes or radiators that are liable to become "air-bound" should also be tried, and air-valves opened, or relief given in other ways, so that the circulation may be free throughout the system while the cold weather lasts.

Freezing of
hot-water
radiators.

Fresh
water.

Many people, including some dealers in heating apparatus for houses, advise drawing all the water out of a steam or hot-water heating system at least once a year, and refilling with fresh water. This may be advisable where the steam is used to drive an engine, as the oil from the cylinder of the engine finds its way into the return water, and accumulates in the boiler; but in the case of heating systems it is injudicious, as every addition of fresh water causes rust in the pipes and other apparatus. It should be kept in mind that water containing dissolved air and carbonic acid acts upon iron, while water that has been heated, and is, therefore, free from dissolved gases, does not act upon it. After the apparatus, therefore, has once been filled with reasonably pure water, and the water heated, no further serious rusting will take place inside the pipes and boiler, even in many years, so long as they remain filled with the same water; while, if the boiled water is drawn off, and fresh water put in, rusting will immediately begin again. Both in hot-water and steam systems there will be some loss, owing to evaporation from the expansion-tank in a hot-water system, and to leakage from valves in a steam apparatus; and it is occasionally necessary, where the water contains much sediment, to draw off the sediment at the lowest part of the system, to prevent clogging. Losses of this kind must be made up with fresh water, which is added to a hot-water system

by pouring it into the expansion-tank, and to a steam-boiler for house heating, usually, by turning it on from the street-supply until the water gauge shows the boiler to be sufficiently filled; but unnecessary addition of fresh water to a system of either kind should be avoided.

CHAPTER VIII

PLUMBING

THE greatest comfort and convenience of modern dwellings is the source of some of the housekeeper's worst anxieties; and a sufficient knowledge of plumbing apparatus to be able to keep it from giving trouble, or to diagnose the malady, if symptoms appear, and have the proper remedy applied, is a valuable possession, for all plumbing apparatus is liable to derangements, more or less serious, at frequent intervals.

Sewer-gas.

The horrors of sewer-gas have been sounded in the ears of the public for many years with so much energy, not to say exaggeration, that every one has some idea of the ways in which it is kept out of a house, and can speak with reasonable intelligence of waste-pipes, traps, soil-pipes and drains, sewers and cesspools, and knows something also, probably, of the system of supply-pipes by which water is brought into the house, and distributed to the various fixtures.

Drainage system.

Of the two main divisions of the science of plumbing, that which concerns the drainage system should first be considered, including the sewer or cesspool which forms the termination of the system. Fortunately for the inhabitants

of cities, sewers do not often give the house-keeper any concern, except as they may occasionally overflow during high tides, or after heavy showers, or furnish a passage for rats into the basement. As rats are good swimmers, they find little difficulty in ascending the sewers and house-drains, diving through the traps, and coming up into the house through the bowl of a basement water-closet; and if a sewer overflows, or is obstructed, it is by the same path that the water will find its way into the house. There seems to be no way of keeping out either the rats or the water, if they are disposed to come in; but the overflowing of a modern sewer into the houses which drain into it is a rare occurrence.

Sewers.

Rats.

A cesspool, on the contrary, is frequently a source of trouble, and the reasons for the trouble, and the methods of preventing it, deserve to be studied by all who have the care of country houses. The ordinary cesspool is a circular pit, usually from six to eight feet in diameter, and eight or ten feet deep, lined with a rough stone or brick wall, laid without mortar, so that the liquid in the cesspool can soak away through the interstices into the ground outside. The top of the lining wall is usually drawn in to form a rough dome, leaving a manhole in the centre, which is, or should be, covered with an iron plate, so that the cesspool can be frequently inspected. In practice, how-

Cesspools.

Covers.

ever, country masons commonly put a flat stone over the opening in the dome, and grade the earth over the whole, the result of which is that extensive excavations have to be made to find it, later, when the drainage system begins to give trouble.

The drain-pipe from the house is entered into the cesspool as near the top as is consistent with a proper fall from the house, so as to keep as much capacity below it as possible ; and the liquid brought by it pours into the pit, and is, for a time, absorbed by the earth at the sides and bottom. After a period varying, according to the nature of the soil in which the cesspool is dug, from a few days to many weeks, or even years, the grease and slime brought by the drain coat over the absorbent surface of the earth around the pit, so that the water no longer soaks away freely, and it begins to accumulate, first in the cesspool, and then in the drain-pipe entering it. If the cesspool is so much lower than the house that the surface of the ground over it is below the basement floor of the house, the water, when the cesspool is full, will overflow upon the ground, causing a certain amount of annoyance to the inhabitants of the house and their neighbors, but probably not exposing them to any real danger. If, however, the basement floor is below the ground over the cesspool, the effect of emptying a bath-tub, or the laundry wash-trays, in the house, after the cesspool is full, will be to cause the foul water

Clogging of
cesspools.

from the cesspool to overflow back into the house, usually through a basement water-closet, this being the lowest fixture connected with the drain.

The overflow of the cesspool liquids into the basement of the house, although not, perhaps, so dangerous a catastrophe as some enthusiasts would have us believe, is a very annoying matter. The use of all the plumbing fixtures in the building must be suspended, often for several days, until the cesspool can be cleaned out; and the basement must be cleared of the foul sewage, the stench of which permeates the house. After the pores of the ground have once become clogged with slime, the cesspool fills up much more rapidly, and, if it has been dug in clayey ground, this experience may recur every few weeks; and the cost of frequent cleaning of the cesspool, for which the licensed contractors often demand extortionate prices, is likely to make a considerable inroad into modest incomes.

Overflow of
drain.

As a cesspool, the walls of which have once become coated with slime, can only be restored to moderate efficiency by a prolonged period of disuse, during which the slime decomposes, or dries and falls off, the usual course, where a house cesspool in constant use fills up, is to make another near by, so as to expose a fresh surface of earth, and lay an overflow-pipe from the old one to the new one. This affords relief until the sides of the new cesspool also become coated with slime, when the process must be repeated.

The remedy
for over-
flowing
cesspools.

As each cesspool saturates the ground about it with decomposing filth, the multiplication of them is more or less prejudicial to the health of the people who have to live near them, and other ways of preventing them from overflowing into the house are to be preferred. The simplest and most efficient of these, where circumstances admit, is to select a site for the cesspool on lower ground, so that the overflow will run out on the surface, instead of backing up into the house; or, if the cesspool is already built, to carry an overflow-pipe from it, with an outlet at the surface of some neighboring low ground. Then, to prevent the formation of a permanent little rivulet of sewage from the overflow, a pump, such as can be bought for a few dollars from dealers in hardware or plumbing goods, should be fixed in the cover of the cesspool, with a suction-pipe reaching nearly to the bottom; and, on the appearance of overflowing sewage on the surface, the contents of the cesspool should be pumped out, and used to water the lawn or garden. The liquid in the cesspool will be found to consist, as it flows from the pump, simply of milky water, mixed, when the cesspool is nearly pumped out, with portions of brown scum, and small white lumps of grease. The watery portion, when thrown upon grass-land or garden soil, is immediately absorbed, all odor disappearing in a few minutes; but the scum and grease may, for the sake of neatness, require raking over, to incorporate them with the earth.

Sewage
pump.

It is hardly necessary to say that the fluid is an admirable, though dilute, fertilizer, and the lover of a garden soon comes to look upon his cesspool, if equipped with a pump in this way, as a precious source of big and brilliant flowers, luxuriant shrubbery, and thick green grass. As the pumping out of the cesspool stops for a time the course of the overflow rivulet, allowing the ground over which it flows to dry and aërate, any annoyance from it is prevented, ground subjected to alternations of sewage saturation and aëration being quite inoffensive.

If a pump is desirable for a cesspool so situated that the water from it will not back up into the house, even if it should overflow, it is still more valuable for a cesspool which, if it overflows, will flood the basement; and such a pump, if not permanently set, ought at least to be available in emergencies for every cesspool. As, however, the cesspool pump is often a more agreeable object of contemplation to the horticulturist members of the family than to the housekeeper, it is desirable to know how its use may be rendered less frequently necessary, by the employment of some more automatic method for absorbing the overflow harmlessly. The best system for this purpose, where the conformation of the ground permits its application, consists of a receiving-cesspool, or settling-basin, which is usually made with tight floor and walls, of brickwork in cement, and a number of lines of open-jointed subsoil

Subsoil
irrigation.

absorption-pipes, laid ten or twelve inches below the surface of the ground, and filled through the medium of a flushing-tank, which receives water from the settling-basin, and, when full, discharges its contents all at once into the subsoil-pipes. The water so discharged finds its way immediately out of the joints between the pipes into the soil around them, and is absorbed, the ground then being left to the influence of the air until the next discharge.

The essential requisite for such a system is that ground shall be available for the distribution pipes at such a grade that they can be laid within twelve inches of the surface without raising the water level in the receiving-basin so high as to flow the sewage back into the house. As the flushing-tank must be filled by the overflow from the receiving-basin, and must discharge at a level from two to four feet lower, according to the variety of flushing-tank used, the surface of the distribution area must be at least three feet below the bottom of the cellar of the house, and should be more, if possible.

Where such a tract, containing a few hundred square feet, is available, no system of sewage disposal for country houses approaches, for efficiency, cleanliness, and economy, that by subsoil irrigation. Although the first cost is much greater than that of an ordinary cesspool, varying from about a hundred dollars for a simple system, suitable for a house with one bath-room, to several

hundred where a large amount of sewage is to be disposed of, the expense of cesspool cleaning, which sometimes amounts to as much in a single year as the whole cost of a better system, is saved, the subsoil-pipes only needing to be taken up once in two or three years, cleared of possible sediment with a stick, and replaced; while there is no danger of the backing of sewage into the house, there are no new cesspools to be dug when the old one fills up, and there is no contamination of the ground, the liquid which flows from the joints of the distribution-pipes being so thoroughly oxidized and transformed by the nitrifying agencies which fill the surface soil that, after many years of use, no trace of sewage matters can be found in the earth around the pipes.

For the economical planning and execution of a system of this sort, even for a small house, professional advice is desirable; but it may be of assistance to those out of reach of such advice to say that the subsoil-pipes should be two-inch agricultural sole tile (Figure 13),

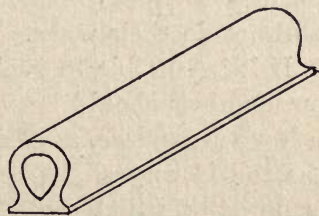

FIG. 13.

laid one-quarter of an inch apart, and the joint covered with a bit of tarred paper while the earth is refilled around them. Many architects lay them on strips of board to keep them in line, and concave tiles can be had for the same purpose,

which have the advantage over boards that they do not rot away and dislocate the whole line of pipes resting on them ; but with care to compact the earth evenly under them, they can be laid with satisfactory results directly on the natural soil. For a house with one bath-room about five hundred feet of subsoil-pipe should be used. This is much more than enough to dispose of all the sewage, even in a clay soil ; but the pipes are cheap, and, as some of them are sure to settle, and fill up with the soft sediment which immediately collects where the flow is checked, ample margin should be allowed. The lines of pipe should be laid with a pitch of one inch in twenty-five feet. With a greater pitch the sewage flows too rapidly to the end of the line, and may make its way to the surface there, unless the last tile is turned slightly downward. With a less pitch the flow is sluggish, and the more distant pipes will not do their work.

If it is possible to avoid it, none of the distribution-pipes should be more than twelve inches below the surface, as the purifying influence of the soil is very slight below that point. There is no danger that the sewage will freeze in the pipes unless it should stagnate in some depression ; or that the ground will freeze around them so as to refuse to absorb the warm flow. For supplying the lines of subsoil-pipe, four-inch vitrified drain-pipe is generally used, jointed with cement, the hubs pointing downward, and with

numerous Y or double Y branches into which the first tiles of the subsoil lines are cemented. The upper end of the line of vitrified pipe terminates at the flushing-tank, and the lower end should be continued by a long line of open-jointed tiles, so that sediment may not collect in the main pipe and cut off the branches. The flushing-tank may be either a siphon-tank, of which many varieties are sold, or a tilting-tank of galvanized iron (Fig. 14), pivoted so

that it will tip over when full, recovering itself when the liquid in it has been discharged. Siphons have the disadvantage of occa-

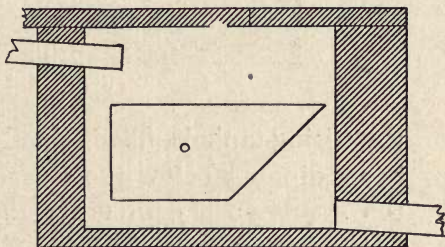

FIG. 14.

sionally filling up with grease, throwing the drainage system out of use until the siphon is removed, and the grease melted out; and they require greater depth than a tilting-tank, but they are much used. Tilting-tanks, if preferred, must generally be made to order, and should work in a special chamber (Fig. 15), filling by an overflow-pipe from the settling-basin, and pouring their contents, when they tip forward, directly into the mouths of the main distributing-pipes, several of which may branch in various directions from the tilting-tank basin, if necessary. The overflow-pipe from the settling-basin, by which

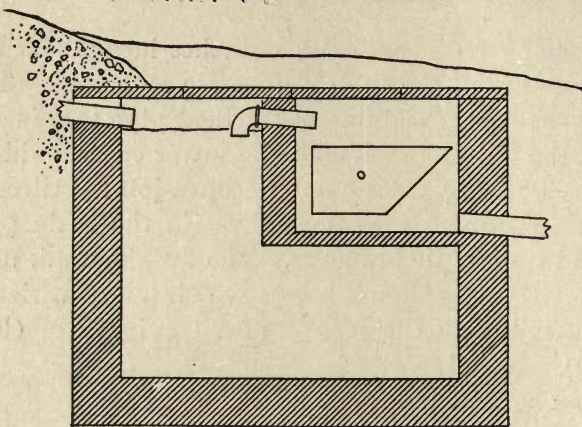

FIG. 15.

the tilting-tank is filled, should be made with a bend, dipping below the surface of the water in the settling-basin, in order that scum may not pass over. The cost of the tilting-tank with its basin is no greater than that of a siphon, and it has the advantage that it never clogs, and can be readily inspected and cleaned without interrupting its functions.

Where the ground about the house is so nearly level that the fall requisite for a proper subsoil irrigation system cannot be obtained, some relief from the annoyance of an overflowing cesspool may be secured by laying lines of open-jointed sole tile directly out from the cesspool, radiating, if necessary, in all directions, for the purpose of increasing as much as possible the surface of absorbent soil reached by the sewage. The pipes should be laid as near the sur-

Subsoil-
overflows.

face as practicable, without allowing the sewage to back up into the cellar, so as to bring the liquid which overflows through them into the porous and oxidizing upper soil, which will take up and destroy a large amount of sewage in this way before the pipes become clogged. After this has occurred, it is a trifling matter to take them up and clean them out; and, if the ground around them has become saturated, they may be relaid in fresh soil.

Even where the house is connected with a sewer, or where the cesspool, or other system of

Main traps
on drains.

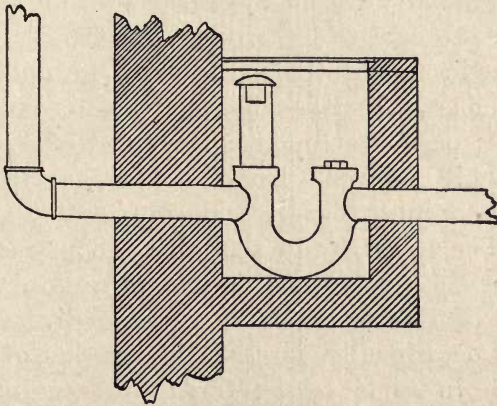

FIG. 16.

disposal, is in good order, sewage will often back up and overflow the basement through the choking of a main trap with grease. The main trap is simply a dip in the line of the main drain, intended to keep air from the sewer or cesspool out of the house pipes, and usually has a hand-hole for cleaning (Fig. 16), closed with a plug or

brass screw, and a "foot vent," or inlet-pipe, on the house side of the trap, open to the air, for admitting air to the system of house pipes. Such main traps are sometimes found inside the house, and sometimes in pits outside, the practice varying with the locality, and with the period at which the house was built. Whatever the style of trap, or the period to which it belongs, it is sure to give trouble sooner or later; and the householder who does not wish to see his basement water-closet occasionally overflowing, or the laundry wash-trays filled with foul water, must take care to have the trap cleaned out at regular intervals. It is still better, in building a new house, to leave the main trap out altogether; or, if it is found in a house already built, to have it removed. Unfortunately, however, the proprietor must consult the local Board of Health before he ventures to do anything about the matter, for there is no question in regard to which Board of Health regulations are so diverse, not to say occasionally unreasonable, as that of main traps. In some towns traps are required on drains connecting with cesspools, and prohibited on those connecting with a sewer; in others exactly the reverse is prescribed; in a third set drains of both sorts must be trapped; and a fourth set prohibits all traps.

Apart from the fancies of Boards of Health, a drain communicating with a cesspool is much better without a trap. Not only does the

absence of the trap remove the source of many overflows of sewage into the basement, and consequent contamination of the house, but it allows free passage of air from the cesspool, which, in such cases, should have a perforated cover, through the house-drain and soil-pipe to the outlet of the latter above the roof. As the air in the cesspool, particularly if it has a perforated cover, is much better than that in the house pipes, lined, as the latter always are, with putrefying slime, the ventilation of the cesspool through the house system tends to purify and aërate the latter, without the slightest risk, if the cesspool is used by only one family, of introducing into the house any germs or infection not already existing in the house pipes; at the same time that, by causing a flow of air downward, through the perforated cover into the cesspool, by means of the strong draught existing in the warm pipes of the house, and thence through the house pipes to the roof, it prevents the smells usually noticed around a cesspool without such ventilation.

Where the house-drain connects with a public sewer, there is a reason for cutting off the access of air from the sewer to the house pipes by means of a trap, in the fact that the sewer contains infectious wastes from many diseased persons, and that, although sewer air has been many times proved to be remarkably free from floating microbes, there is reason to think it may, if in-

Sewer-traps.

haled, produce in the system a condition of predisposition to infection from certain causes. Of late years, however, while house systems of waste-pipes are better inspected, and made more secure against leakage of air, than formerly, the practice of engineers in building sewers has been modified, and the free ventilation now adopted has materially changed the character of sewer air. In many towns and cities the use of main traps on house-drains connecting with sewers is prohibited, for the express purpose of allowing the sewers to ventilate through the house pipes; and where the main trap is still insisted upon, the sewers are generally ventilated by open manhole covers in the streets. It is hardly necessary to say that an incautious person, passing one of these open manhole covers, is quite likely to inhale a larger dose of sewer air than he would get by living years in a house without a main trap; so that, as sewers are now built, the risk of infection from them is lessened, rather than increased, by leaving out all main traps, and utilizing the soil-pipes of the houses as ventilation flues, drawing fresh air in at the open manhole covers; while the danger and annoyance resulting from the almost inevitable choking of main traps are avoided.

Cleaning
traps.

Where the trap exists, it is, or should be, always accessible, either from the inside of the house, or by a manhole outside, so that it can be cleaned out through the hand-hole. In most

houses this operation must be repeated every few months, as the dip of the trap collects sediment, and, as the flow of warm, greasy water is checked by the bend, the grease chills and adheres to its sides. Warning is usually given of the approaching stoppage of the trap by the slow running off of water from the wastes of the basement fixtures, and it should then be cleaned at once, before a complete stoppage causes an overflow into the basement.

Even where there is no trap on the main drain, the drain-pipe itself may clog with grease if it is laid with insufficient fall or is exposed to cold air. Contrary to the general belief of plumbers, a small pipe is less likely to choke with grease than a large one, for the reason that the current is more rapid in the small pipe, and the surface of the stream is smaller, so that the warm, greasy water from the kitchen and pantry sinks reaches the sewer or cesspool before the grease has had time to become chilled and adhere to the sides of the pipe; but, as servants of a certain class are apt to put old rubber shoes, rags, scrubbing-brushes, and other articles of various kinds down the drain, the diameter of the main pipe must be sufficient to accommodate such objects without complete stoppage, five inches being generally enough. Cooks and other servants also differ greatly in regard to the amount of grease which they waste through the sinks; so that, while one may keep a drain free

Grease.

for years, another will choke it in a few months. The stoppage from this cause is likely to occur where the pipe passes through a cold place in the cellar. In such a place the walls of the pipe become so cold as to solidify the particles of grease carried past them by the current. These solidified particles attach themselves to the sides of the pipe, and in their turn become cold, and catch and solidify others, until the pipe gradually fills with a mass so hard as to require a chisel to remove it.

Cleanouts.

Every main drain-pipe in a house, and the principal branch drains, ought to be laid with a Y branch and brass cleanout screw at every change of direction, so that the whole length of the pipe can be reached and scraped out when required. If this is done, the clearing out is a simple operation, and in an hour or two the pipes are in perfect order again. Where, however, this precaution is neglected, it is often necessary to break the main pipe, or cut large holes in it, to reach the accumulated grease; and after this has been removed, with great difficulty and expense, the holes cannot be properly stopped, but are usually covered with patches of sheet lead, tied on with wires, which afford a very imperfect protection against the escape of sewer-gas. Where the drain-pipe is so laid as to make it necessary to cut into it to remove grease, the choked pipe should be entirely removed, and a new one substituted, and one or more Y

branches put in, to enable proper cleaning to be done. The expense of this will not be very much greater than that of cutting a pipe and protecting it again, and it will soon be repaid in the saving of cost in subsequent cleanings.

The lesser traps, connected with the various plumbing appliances, which are necessary to prevent air from the waste-pipes from entering the rooms, are also liable to fill with sediment or grease; but, as they are usually accessible, and fitted with cleanout screws, there is seldom any difficulty in clearing them of deposit when clogged. The trap under the kitchen sink is most troublesome in this respect, as it is sure to choke with grease at more or less frequent intervals; but the intervals may be greatly prolonged by an occasional treatment with caustic potash, which can be obtained in small, iron cans, and, by converting the grease into soft soap, facilitates its solution and removal. The simplest way to apply the potash is to turn out half the contents of a can over the strainer of the sink at night, and leave it, with a slight drip of water from the warm-water faucet to dissolve it, and carry it down to the trap. In the morning the potash will have disappeared, and the flow of waste water from the sink will be found much freer than before. It is important to use caustic potash, instead of caustic soda, which is sometimes substituted for it, as the latter forms with grease a hard soap, which is much less

Fixture-traps.

Potash treatment.

easily removed by a stream of water than the soft soap formed by the potash. Neither caustic soda nor potash should be allowed to touch glazed earthenware or porcelain, or the enamel of an enamelled-iron sink, as either of them will dissolve the glaze; but they will not affect brass, lead, or iron.

It will be necessary to return to the subject of waste-pipes and traps in connection with the treatment of plumbing troubles; but some consideration of the different appliances used in dwelling-houses should precede this.

Sinks.

The kitchen sink, the pantry sink, and the laundry wash-trays are only so many different forms of the same apparatus, into which hot and cold water are conducted through pipes and faucets of various shapes, for use, and from which, after use, the water flows away through some sort of trap into the drain. The kitchen sink may be of plain iron, galvanized iron, enamelled iron, solid earthenware, soapstone, or slate, according to the taste of the owner, and with or without a high back of the same material, to prevent spattering the wall. The water is generally allowed to escape from a kitchen sink through a brass strainer, to separate the solid matters thrown into it, and prevent them from choking the waste-pipe; and, as there is never any occasion for filling the kitchen sink with water, it has no overflow.

Kitchen
sink.

A pantry sink, on the contrary, is filled with

water when in use; and, in order to prevent it from overflowing, it is always provided with some sort of pipe, generally protected with a strainer, which opens into the sink, near the top, and communicates with the waste-pipe, so that any surplus water that may be drawn escapes through this overflow-pipe, instead of flooding the pantry floor. In order to keep the water from running out through the waste-pipe at the bottom of the sink, when the latter is to be filled, some sort of plug must be provided; and in this plug, and the overflow, are found the principal variations of the apparatus. The older pantry sinks were of tinned copper, with a rounded bottom, like a wash-basin, with a hole in the bottom, which could be closed by a brass plug, attached to a chain, and an overflow consisting of a simple pipe, connecting with the main waste-pipe, and entering the side of the sink, with a grated opening. This form of pantry sink had several disadvantages, one of which was that, when careless servants put several dishes at once into them, the rounded bottom afforded the dishes an opportunity to slide down, and come into collision with each other, to their damage; while another defect was that the plug and chain interfered with the dishes, and, when hastily pulled out, often fell upon, or displaced dishes, and broke them; so that this form is now generally abandoned in favor of the flat-bottomed sink, which may be either of tinned

Pantry
sink.

copper, or of German silver, the latter having the advantage that its bright appearance can be renewed indefinitely by polishing, while tinned copper soon loses its coating of tin. In order to avoid the use of the plug and chain, as well as to provide an overflow-pipe more easily cleaned than the old one, most copper and German-silver pantry sinks are now made with a recess, in which stands a short pipe, open at the top and bottom, the lower end of which fits into the opening of the waste-pipe. When this "standing-waste," or "stand-pipe," is in place, and the water is turned on, the sink fills to the top of the stand-pipe, and the water then overflows through it; while, by lifting the stand-pipe out of its socket, all the water in the sink can escape through the waste. As the stand-pipe overflow is very much shorter than the old-fashioned fixed overflow, and is readily cleaned, its use prevents the sickly odor characteristic of pantries in old houses, which proceeds, usually, from the decomposing grease which lines the overflow, and is inaccessible there. By recessing the stand-pipe it is kept out of the way of the dishes, and the plug and chain are, of course, unnecessary where it is used. Most of the solid earthenware and enamelled-iron pantry sinks, which are often used in preference to those of copper, are fitted with recessed stand-pipes in the same way.

As there is often a question, in fitting up a new house, or refitting an old one, whether cop-

per, German silver, porcelain, or enamelled-iron pantry sinks should be used, it may be worth while to observe that the solid porcelain sinks, although beautifully clean, and very strong and enduring, have a rather bad reputation for breaking dishes, and are, in consequence, usually fitted with a piece of brass or galvanized wire netting, which lies on the bottom of the sink, and forms a sort of cushion, on which a dish may be dropped with comparatively little risk of injury. Enamelled-iron pantry sinks are also beautifully clean, although less durable than those of solid porcelain; but, being hard, they also require a wire cushion on the bottom. Of the metal sinks, those of German silver are the handsomest, and also much the most expensive; the tinned-copper sinks being the cheapest and least attractive of all, but also the least destructive of crockery.

The laundry wash-trays, which are made of soapstone, slate, enamelled iron, and solid earthenware, resemble pantry sinks in having a provision, usually a plug and chain, for retaining the water in the tray; but, unfortunately for the laundresses, who, if they are forgetful, often find the laundry floor flooded, they are not furnished with overflows, unless in very exceptional cases.

It cannot be said that there is any quite satisfactory material for wash-trays. Soapstone, either natural or artificial, is much used, but some kinds are acted upon by water, and soon become pitted and rough. Slate is not affected by water,

but is brittle, and sometimes cracks unaccountably; and enamelled-iron and solid porcelain trays, although otherwise clean, durable, and attractive, have the disadvantage that they must be made singly, and set side by side, so that, in the shifting of the clothes from one tray to another which the laundress finds necessary, water finds its way between the trays to the laundry floor. Sets of trays, both of porcelain and enamelled iron, are provided with brass caps, to cover the joints between them, but this is less effective than to make them with the front, back, and bottom each in one piece, as is usually the case with the slate and soapstone trays.

Soapstone and slate trays usually have soap-cups, either of stone or metal, attached to them; but separate rubbing-boards must be used. With the porcelain and enamelled-iron trays the soap-cup is of metal; and, in a set of porcelain trays, one tray usually has a rubbing-board formed in the porcelain.

It does not follow, however, that, because a set of wash-trays attracts the owner by its whiteness and polish, it will be equally pleasing to the laundress; and the prudent housekeeper, in choosing these appliances, will do well to consult with the person who is to use them. Many laundresses dislike the porcelain rubbing-boards, as being too hard, and many more complain that the porcelain and enamelled trays, which are usually much deeper than the stone ones, are so deep

that they cannot reach to the bottom of them; so that it is desirable to forestall complaints.

In some parts of the country, the laundry is usually fitted with a copper wash-boiler, set in brickwork, and arranged with a flue, and with feeding-door, ash-door, and grate, so that the clothes can be boiled before they are washed. Where it is practicable, the boiler is placed close to the wash-trays, so that the clothes, after boiling, can be pulled directly over into the wash-trays for final treatment, without having to be carried, hot and dripping, across the room. There is no doubt that the thorough sterilization incident to the boiling of the clothes is hygienically advantageous, but it is a severe trial to delicate colors, and housekeepers and laundresses are divided in their opinions on the subject.

Wash-boilers.

The wash-basin resembles in principle the pantry sink, having means for retaining the water in the basin when desired, and an overflow for carrying off a surplus; but there is great variety in the arrangement of these features, due to the efforts of manufacturers to devise an apparatus sufficiently clean and neat to be placed in or near a sleeping room.

Wash-basins.

There is more difficulty about this problem than might be imagined. The "set basins" of twenty or thirty years ago, with their inaccessible overflows, consisting of a cluster of perforations in the side of the basin, communicating with a pipe which led down, and joined the waste-pipe above

the trap, soon began to give forth a sickly odor from the decaying soap with which the overflow-pipes rapidly became lined; while, if they were left unused long enough for the water in the trap to evaporate, which was not more than two weeks, in hot weather, the drain or sewer began to ventilate through them into the room; so that fashion, which once prescribed such a basin in nearly every bedroom of a good house, now usually restricts them to bath-rooms and dressing rooms. They are, however, much better designed now than ever before. The old-fashioned inaccessible overflow, which formerly communicated with a lead pipe two or three feet long, now, where it is still used, is formed in the porcelain of the basin, and is only about ten inches long, so that it can be tolerably well washed by running water through it; and, in many cases, the strainer, which prevents cakes of soap from getting into it, is hinged or made otherwise removable, so that it can be thoroughly cleaned by means of a sponge or rag tied to a wire. Other wash-basins are recessed, and provided with stand-pipes, like those of a recessed pantry sink, various means being employed for raising or inclining the stand-pipe to let the water out of the basin; and still a third class has the stand-pipe outside of the basin, but set in a larger tube, communicating with the basin. This arrangement is neat in appearance, and is satisfactory if the stand-pipe and the enclosing tube are kept clean by frequent

sponging out, the cover over them being always made removable for this purpose. Other basins still have waste-plugs in the bottom, operated by levers from the outside, instead of by a chain. As with the waste devices, the basin-cocks through which wash-basins of all sorts are supplied assume every shape that the manufacturers think will sell, some having the hot and cold supplies combined, with or without a mixing-ball, while others are furnished with ring-cups or other attachments; and, where it is important to prevent waste of water, many varieties of self-closing cocks are used. In general, however, the simplest forms are the most satisfactory; and self-closing cocks, although sometimes necessary, are undesirable for dwelling-houses, on account of the concussion which they produce in the pipes in closing under heavy pressure.

In many respects a bath is simply a large wash-basin, with supplies, waste, trap, and overflow essentially like those of a wash-basin, but on a larger scale. Baths. The best tubs, and also the most expensive ones, are of solid earthenware, or porcelain, as it is incorrectly called; but such tubs are very heavy, and consume a great deal of hot water, on account of the chilling effect of the mass of cold material in them. Recently, however, an attempt has been made to furnish a lighter and cheaper porcelain tub, which should be a very desirable article for dwelling-houses.

Next to the solid porcelain tubs, the ones most

generally preferred are those of enamelled iron. These, if well made, are beautifully clean and attractive, and are comparatively light, so that they do not burden the bath-room floor, while they do not seriously chill the hot water. The best qualities are guaranteed by the makers for three years against the chipping of the enamel. The enamelled, as well as the solid porcelain tubs, are set without wooden casings, so that there are no concealed spaces about them to harbor water-bugs.

Many bath-tubs are, however, made of tinned copper, set in a casing either of wood or iron, and have certain advantages. Besides being somewhat cheaper than the enamelled tubs, they do not cool the water in them, and accidental contact with the sides does not chill a sensitive skin. They are also much less slippery, when wet with soapy water, than the porcelain or enamelled tubs, and are thus, perhaps, better suited to the use of old or feeble persons. They soon become shabby, however, through the wearing off of their coating of tin, and, although this does not impair their usefulness, it makes them less popular with housekeepers than the more modern varieties. In very old houses similar bath-tubs are sometimes found, lined with lead instead of copper, the lead being usually painted; and tubs of painted cast iron still linger in old hotels; but both of these have long been obsolete for new work; and the silver-lined

bath-tubs of some of the New York mansions, or the Italian baths, hollowed out of a block of marble, are not likely to become popular here.

Most good bath-tubs are now fitted with a standing overflow, in place of the inaccessible pipe and strainer formerly in use; and it is common to place the stand-pipe outside of the tub, communicating with it by a short pipe. A few years ago, when the inaccessible bath-overflow was discarded, its place was taken by a "standing-waste," consisting of a stand-pipe in the tub itself, which was lifted out of its socket to allow the water to run out of the tub, serving at the same time as an overflow; and, when not in use, rested on two plated brackets at the foot of the tub. This was a very clean and efficient device, and is still extensively used; but, unless the tub is a long one, the stand-pipe is in the way of the bather's feet; and, being heavy, it is liable to slip out of wet hands, and chip the enamel of the tub, or make dents in a copper lining. To get the pipe out of the way of the feet, recessed tubs were then made, similar to the recessed pantry sinks still so popular, and the standing-waste was often set permanently in place, requiring only to be turned, or lifted slightly, to allow the water to escape. This arrangement is more convenient than the plain tub and stand-pipe, but the recess requires special cleaning to remove the soapy scum which collects in it; and the outside overflow, which can be lifted out

Bath-
overflows

and cleaned occasionally, in connection with a plain tub, and a plug and chain waste, is generally satisfactory.

Bath-supplies. For supplying bath-tubs plain and combination cocks in great variety are sold, with and without ring-cups, soap-cups, and shampoo and shower attachments; but, for dwelling-houses, separate hot and cold water supplies are usually most desirable. In hotels, where the hot and cold water are under the same pressure, combination bath-cocks answer very well; but the system of heating water in private houses is totally different from that used in hotels, the hot water being usually under much lower pressure than the cold water, and the result of this is that the cold water forces its way first out of a combination-cock, pushing back the hot water, so that a mixture of agreeable temperature can only be obtained in the tub by drawing hot and cold water alternately; and, in using a shower or shampoo attachment, the trouble is intensified. In permanent shower-baths, which are rapidly becoming popular for private houses, this difficulty is avoided, to some degree, by providing a reservoir overhead, in which the hot and cold water can mix before escaping, a "mixing-ball" being often added to facilitate the process.

Shower-baths. Besides the shower, needle-baths, in which the bather stands in the centre of sets of perforated pipes forming nearly a circle around him, are often used; but with these, as with the shower,

Needle-baths.

the result is likely to be disappointing unless the pressure of the hot and cold water can be equalized by means similar to those employed in hotels and public baths.

The last important plumbing appliance remaining to be described is the water-closet, the most unsatisfactory and dangerous of all if improperly made or set, or badly managed. As the pan-closets, the valve-closets of the Hellyer type, and the plunger-closets of the Jennings, Demarest, and other varieties are no longer in the market, and are found only in old houses, it is unnecessary to say much about them. The pan-closet, with its huge receiver full of filth under the pan, is incurably bad, and, where found in an old house, should be immediately replaced by something better. The valve-closets, if well put in, are practically safe as long as the valve remains tight; and the plunger-closets can be kept in safe condition by lifting out the plunger frequently, and cleaning it and the plunger chamber. Where, however, any of these old-fashioned closets become so worn that the water is not held in the basin, they should be discarded, and something more modern set in place of them.

Among the modern closets there is nothing, perhaps, more satisfactory, considering its simplicity and freedom from repairs, than the short flushing-rim hopper, which can be had, including the trap, in a single piece of porcelain (Fig. 17), or with a porcelain basin, bolted or clamped to

Water-closets.

Short
hoppers.

a lead or iron trap (Fig. 18). It is curious that the first water-closets made, after the invention of the trap, about 1840, rendered it practicable to have such an apparatus within the walls of a dwelling-house, were substantially the same as the modern hopper, the improvements consisting in the substitution of earthenware or porcelain, as a material, for the cast iron of the early

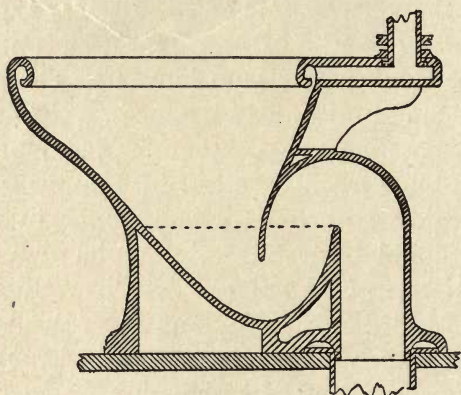

FIG. 17.

hoppers, and the addition of the flushing-rim. In its present form, the short hopper presents the great advantage of having no moving or concealed parts, while the contents of the basin remain in plain sight until they are washed entirely out beyond the trap, never to return or give trouble, by a flush of water which, entering on all sides through the flushing-rim, and descending with considerable force, washes the sides of the basin. Unfortunately for the popularity of an

excellent apparatus, the efficiency of this washing action of the flush is not all that could be desired. If the closet is used when the sides of the basin are dry, they will receive a stain which the force of the flushing-water is insufficient to remove; and such stains, although really harmless, are unpleasant in appearance. They can be avoided by a preliminary flushing of the basin, to

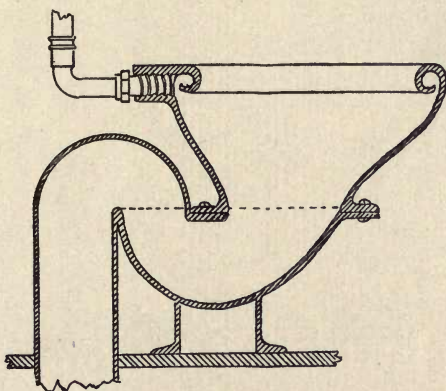

FIG. 18.

wet the sides and prevent adhesion; but this is generally forgotten, so that short hoppers, in practice, need frequent scrubbing to keep them presentable.

A modification of the short hopper has the bend of the trap raised, so as to hold a larger body of water in the basin, and in this way prevent the staining of the sides (Fig. 19); but a strong flush is needed to carry this increased volume of water over the additional height of

Wash-down
closets.

the bend of the trap, without leaving floating material in the basin.

Siphon-
closets.

To meet the two requirements, of keeping a large volume of water in the basin, and of having it entirely removed by the flush, the principle of the siphon is now extensively applied to closets. Every one knows that a bent tube, having one leg longer than the other, will draw all the water out

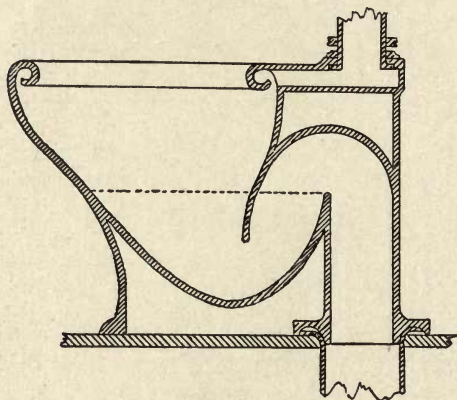

FIG. 19.

of a tumbler into which the short leg is plunged, if the tube is once filled with water, by sucking at the long end or otherwise. In applying this principle to a water-closet, the trap and the waste-pipe beyond form the siphon, the basin forming a part of the short leg; and the problem to be solved is how to fill the bore of the pipe beyond the trap completely with water, so as to create a suction which will bring the siphon action into play, and draw over, by atmospheric pressure, all

the contents of the short leg of the siphon, including the basin. In most closets, this result is accomplished by means of a "jet," which is seen as a small hole opening almost at the bottom of the basin on the side opposite the trap, and is supplied through a conduit formed in the earthenware of the basin, communicating with the flushing-rim. When the closet is flushed, a part of

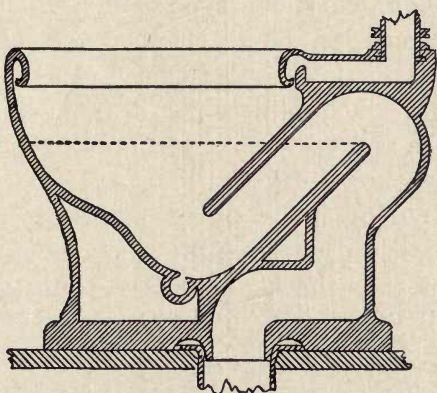

FIG. 20.

the flushing-water rushes down this conduit and out of the jet, which is so formed as to throw the water in the direction of the axis of the trap. Partly by the additional quantity of water so supplied, but still more by the force with which it is projected (Fig. 20), enough liquid is thrown at once over the bend of the trap to fill the waste-pipe beyond, which is slightly contracted for the purpose; and, as soon as this pipe is completely filled, the atmospheric pressure on the surface of

the water in the basin comes into action, and the whole is sucked over the bend of the trap into the waste-pipe. The air rushes after it, and again fills the pipe behind the descending column of water, leaving the apparatus ready for a repetition of the process ; while, as the flushing-valve closes, enough more water trickles in to refill the basin to the normal depth.

This is an excellent type of closet, and is deservedly popular, being clean and efficient, and having no moving parts to get out of order, and no concealed spaces in which filth can collect unseen. The most serious objection to it is that the jet-tube, being below the bottom of the basin, is not cleared of water by sponging out the trap, and unless special means are taken to remove the water, in case the house is to be left vacant in winter, it will freeze in the jet-tube, and destroy the closet. It is possible to remove the water in the jet-tube by means of a small sponge, tied to a wire, and inserted through the orifice of the jet after the basin has been sponged out ; or by unscrewing the brass plug on the outside of the closet which some manufacturers provide for the purpose ; but plumbers usually unscrew the bolts and couplings, and take the closet up, and reverse it, so as to let the water run out of the jet-tube. The closet is reset in its proper position either immediately, or when the house is again occupied in the spring ; but there is always some uncertainty whether it will be reset with due care and

skill, and a few minutes' time spent with a wire and a little sponge in getting the water out of the orifice of the jet, instead of taking up the closet, will often save the householder the unwelcome experience of finding the closet broken, through careless tightening of the bolts and couplings in resetting, or of suffering all summer from leakage of sewer-gas, owing to imperfect puttying of the joint around the flange of the closet when reset. In order to avoid the risk of these troubles, without spending time in the slow sponging out of the jet-tube, some plumbers simply throw a handful of salt into the basin, without even sponging this out. The salt dissolves in the water in the basin, and finds its way into that in the jet-tube; and, as a strong solution of salt does not freeze into a hard mass, but, if at all, only into a sort of icy mud, this will protect the closet against bursting by freezing. If the closet-basin is made of "vitreous china," a sort of porcelain much used, and very desirable for such purposes, the salt can be used with safety; but a strong solution of salt should not be allowed to stand in contact with ordinary earthenware, or to touch brass sockets, plugs, or other fittings.

A more recent form of siphon-closet dispenses with the jet, and obtains the filling of the waste-pipe beyond the trap, essential to siphonic action, by making a sharp bend in it (Fig. 21), so as to impede the current momentarily, and throw the water back on itself, without diminishing mate-

Dececo
closets

rially the size of the pipe. This answers the purpose of setting up siphonic action perfectly, and the fact that the closet has no jet-tube to freeze and burst, and can be entirely cleared of water by sponging out the basin, is often a great advantage.

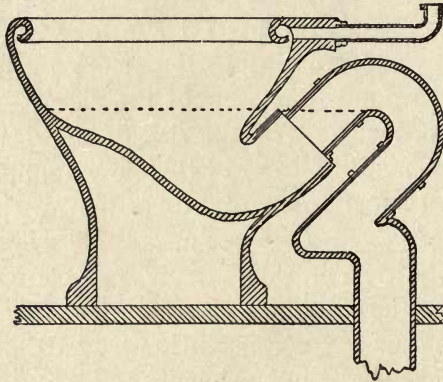

FIG. 21.

Washout-
closets.

Another type of closet, which formerly enjoyed a rather undeserved popularity, is the "washout," or, as it is often called, from the trade-name of the best known pattern, the "Brighton" closet (Fig. 22). This has a shallow basin, with flushing-rim, so arranged as to drive the water standing in the basin either backward or forward, according to the pattern used, into a trap, which is formed in the earthenware under the basin. In some forms of this closet the trap is nearly inaccessible, and in all it is practically out of sight; so that, even if the basin is clean, the hidden trap may be very foul, and, when in that condition,

sends its odors freely into the room. With a sponge, tied to a stout wire, the trap can be easily cleaned, if necessary, so that a washout closet, properly cared for, is satisfactory enough ; but it is better, in plumbing appliances, that the need of cleaning should be manifest to the eye before it makes itself known to the nose.

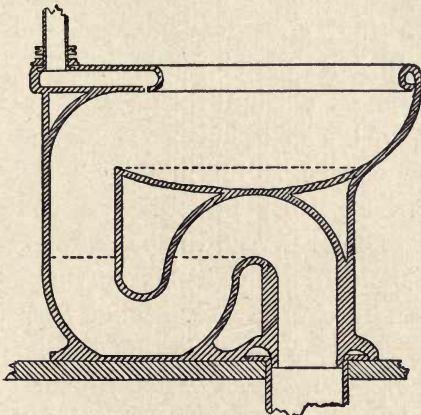

FIG. 22.

Nearly all modern water-closets can be had with "local-vent" connections, by which air may be drawn from the basin of the closet, directly under the seat, to some heated flue. In most cases these local vents, if the closet has been ordered with them, are simply plugged up by the plumber ; but it is very desirable to connect them, by lead, copper, or other pipe, with some flue that can be warmed. The range-flue is usually chosen, and is the most suitable, if its draught is good

Local vents

enough not to be checked by the vent-pipe. Although the local vent is small, being, for house water-closets, from two to three inches in diameter, the slow current through it does much to purify the air of the small rooms in which water-closets are placed.

As a rule, water-closets in dwelling-houses receive their supply of water from a copper-lined cistern, or tank, usually supported by brackets on the wall above the closet, into which the water flows through a small pipe, and a ball-cock, arranged with a float, which shuts the water off when the cistern is full; while a cistern-valve, which can be lifted by pulling a chain or rod attached to a lever, allows the water to flow out rapidly for flushing. The cistern is usually provided with an overflow connected with the flush-

pipe, so that, if the ball-cock fails to act properly in shutting off the water, the surplus will escape through the water-closet to the drain, instead of overflowing on the floor.

Every plumbing fixture must have a trap of some kind to prevent foul air from coming back from the drain through its waste outlet. In its simplest form a trap is

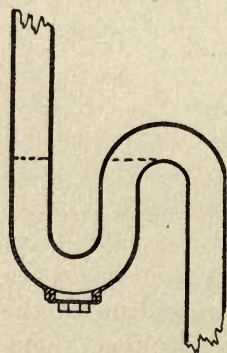

FIG. 23.

merely a downward bend in a pipe, so deep that the upper wall of the pipe dips into the water

Water-closet cisterns.

Traps.

held in the bend, the extent to which it dips being known as the depth of the seal. With slight modifications this is the trap (Fig. 23) most commonly used for wash-basins, water-closets, and other apparatus where grease is not likely to get into the waste.

For kitchen sinks, pantry sinks, and wash-trays the plain dip, or S trap would soon be choked with grease or sediment, so that it is usual to furnish these with a "round trap," consisting of a lead cylinder, from four to six inches in diameter, with an inlet-pipe near the bottom, and an outlet-pipe near the top (Fig. 24).



FIG. 24.

The cylinder is large enough to accommodate a considerable accumulation of grease, without cutting off entirely the flow of water through the trap. To clear out the grease, when necessary, round traps are always fitted with brass trap-screws, at least four inches in diameter, this being the smallest size that will admit the hand; and it is not a difficult matter to unscrew the trap-screw with a wrench, dig out the white mass of solidified grease, and close the opening again. For baths, although accumulations of grease are not to be feared, it is very common to use a round trap, set in the floor, with the trap-screw flush with the surface of the floor, and either left exposed, or covered with a nickelled plate. As the waste outlet of a bath is necessarily near the floor, this

Round
traps.

form of trap is more conveniently connected than an S trap would be, while the four-inch trap-screw in the floor makes it easy to recover rings, precious stones, and other articles which are frequently lost in baths. The stones from rings also often fall into basin-wastes, but as the basin trap is always, in a modern house, high above the floor, the small screw which is generally set in the bottom of S traps, as shown in Figure 23, can be removed, when everything in the trap will fall into a dish or pail previously set underneath to receive it. Water-closets often have their trap formed in the porcelain itself, and, as the waterway is always large enough to admit the hand, they are accessible for cleaning or for recovering lost objects, without trap-screws.

Back vents

An inspection of the trap under any plumbing fixture will show the inlet-pipe and outlet-pipe, but, in most cases, a third pipe will be found, extending upward, either from the trap itself, or from the outlet-pipe, near the trap. This pipe is the back vent, and is intended to prevent the removal of the trapping-water by siphonage. The action of a siphon water-closet, by which, as soon as the waste-pipe beyond the trap is filled with water, all the contents of the basin are drawn over by atmospheric pressure, shows what may happen in any S trap, or in a round trap partly filled with grease, if the bore of the outlet pipe should become completely filled with water, as may easily happen if a slight obstruction

should momentarily check the flow. In order to prevent the loss of the trapping-water in this way, and the consequent opening of a passage for sewer-gas through the trap, an air-pipe, or back vent, is carried from the outlet side of the trap to a main air-pipe, through which air can be drawn to supply the vacuum caused by the descent of a solid column of water, without disturbing the sealing-water of the trap.

The main waste-pipes, in dwelling-houses, are almost always of cast iron, put together with "caulked joints" of melted lead, wrought-iron pipe, with joints screwed together, being used only for public buildings, and for the most expensive class of dwellings; and the main air-pipes, which are closely connected with the waste-pipes, are usually of the same material. The smaller waste and air pipes, and the supply-pipes, may be of lead, iron, or brass, or of a mixture of these materials. As waste and air pipes do not have to endure great pressure, the smaller ones are usually of lead, which has the advantage of being easily joined, and being practically exempt from corrosion; but supply-pipes are often subjected to great pressure, which only a very thick lead pipe can resist, and some waters, particularly rain-water, or very pure river or spring water, dissolve lead in sufficient quantity to make them slightly poisonous. Where this is the case, the best material for supply-pipes, although an expensive one, is brass. Iron supply-pipes, which are

Pipes.

much cheaper, sooner or later fill up with rust. Galvanizing or enamelling will postpone the rusting, often for a considerable period, but galvanized pipes frequently impart an injurious contamination to the water that runs through them. The tin-lined and lead-lined pipes, which are now much used, are good if put in with care, but, if handled by inferior plumbers, who cut them without proper caution, the iron may be exposed at a joint; and the pipe may fill with rust from a small surface of iron left bare in this way, as the galvanic action between the metal of the lining and the iron pipe assists greatly the corrosion of the latter.

Tin-lined
pipes.

Brass pipes.

Brass pipes, on the contrary, are not subject to corrosion by any ordinary water. They are, however, unless annealed, liable to internal strains, which often cause them to split without warning, and they should be of "iron-pipe sizes," the light pipes known under the name of "plumbers' tubing" being too thin to make substantial joints; but, if of proper weight and quality, and intelligently put together, and kept from freezing, brass supply-pipes are practically everlasting.

Nickel-
plating.

It is usual in "open plumbing" to make all the traps and pipes, including supply, waste, and air pipes, which are exposed in bath-rooms, of brass, nickel-plated, for the sake of the bright and clean appearance which they present; but nickel-plating, where it cannot be easily reached for clean-

ing, soon becomes covered with oxide, of a dingy, greenish gray, and it is becoming common, instead of plating such pipes, to bronze them with silver or aluminum bronze, which can be applied to lead and iron pipes, as well as to those of brass, and is easily renewed, if necessary.

Even where the cold-water supply-pipes are of lead, it is common to make the hot-water pipes of brass, for the reason that lead hot-water pipes, through alternate expansion and contraction, as the hot water is drawn through them, gradually acquire a series of bends between their supports, which are unsightly, and check the flow of water through them; so that the strong and rigid brass pipes are more satisfactory. Brass hot-water pipes must, however, be put up with angles in their course, so that the expansion and contraction may be taken up by the spring of the angle, as a long, straight pipe, held firmly at the ends, will soon leak at the joints, through the strain which is brought upon them by contraction and expansion.

Hot-water
pipes.

As hot-water pipes often give trouble in other ways besides leaking at the joints, it is desirable to understand the principles upon which they are, or should be, put in. The manner in which the water in the bath-boiler is heated from the water-front in the kitchen stove has already been described in treating of the latter. The bath-boiler itself is a copper or galvanized-iron cylinder, mounted on a stand, with a coupling in the

Hot-water
piping
system.

Bath-
boilers.

side, to receive the flow-pipe from the water-front of the range, another in or near the bottom, for the return-pipe to the range, and three or more couplings in the top. The middle coupling on top connects with a tube which extends down, inside the boiler, nearly to the bottom. This is used for the supply of fresh cold water which enters the boiler to replace the hot water that is drawn off; and the tube inside the boiler serves to conduct it to the bottom of the boiler without allowing it to mix with the hot water which occupies the upper portion of the latter. The other couplings in the top of the boiler are for the pipes which carry the hot water over the house. The action of the boiler, as thus fitted up, is very simple. So long as no hot water is drawn from it, the water that it contains simply circulates through the water-front of the range and back again, getting gradually hotter in the process; but, as soon as any hot water is drawn from the boiler, by means of the pipes which extend from its top, an equivalent amount of cold water descends through the inside tube to the bottom of the boiler, and thence to the water-front, where it takes its place in the general circulation.

Strictly speaking, this constitutes all the necessary part of a hot-water system, including a provision for supplying fresh water as hot water is drawn off; a water-front for heating the water; a boiler, or more correctly, a reservoir, for stor-

ing a reserve of water heated in the range, and a system of pipes to distribute the water from the boiler; but, if no circulation is provided except that between the water-front and the boiler, the pipes above the boiler will be cold; and, on opening a hot-water faucet anywhere, a certain amount of cold water, depending upon the length of the pipe, must be drawn before any hot water reaches the faucet.

To obviate this annoyance, it is usual to provide, where circumstances permit, one or more secondary circulations, by which the main hot-water pipes, after reaching the highest fixture that they supply, are carried over in a loop, and brought down again to the boiler, entering the latter near the bottom. In this way the water in the loop is constantly rising hot from the boiler, passing through the circulation-pipe, and back again, only slightly cooled, to the boiler; so that hot water can be drawn immediately from any faucet on the line. This arrangement is, however, only practicable where the hot-water system is supplied from a tank in the upper story, for the reason that bubbles of air collect in an upward bend of any pipe conveying water, and will stop the circulation unless they are allowed to escape; so that, where a circulation-pipe is brought back to the boiler from the highest part of a hot-water system it is necessary, in order to preserve the flow through it, to carry up from the highest point an expansion-pipe, which is extended above the tank

Secondary
circulation.

Expansion-
pipe

supplying the hot-water system, so that it can be left open without allowing the water to overflow. In practice the expansion-pipe is usually terminated by a bend, the mouth of which is just above the overflow of the tank, so that, if foam and bubbles rise through it, as they are likely to do with some waters, the drip will be carried safely away.

With a "pressure system" of hot-water supply, in which the boiler takes water directly from the street main, without the intervention of a tank, secondary circulations are impracticable, as the expansion-pipe necessary for clearing them of air would continually overflow; so that, with a system of this sort, a preliminary flow of cold water from the hot-water pipes is unavoidable.

CHAPTER IX

TROUBLES WITH PLUMBING, AND THEIR REMEDY

THE disorders to which plumbing in houses is subject may be divided into three classes: those connected with the drains and waste-pipes; those which appear in connection with the supply-pipes; and those which affect fixtures of various kinds.

Naturally, the first symptom of a defect in the waste-pipes of a house is a disagreeable odor, the locality of which will, to a certain extent, indicate its cause. In modern houses all the pipes, including the waste-pipes, are exposed to view, or can easily be examined by removing a casing of some sort; and, unless the trouble is quite evidently connected with some fixture, it is well to trace in this way the whole length of the main soil-pipe, examining particularly the joints. It is not unusual to find that settlement, or the shrinkage of the floors, has pulled the lead with which the joints of cast-iron pipes are made tight partly out of the socket; and, in this case, a few minutes' work with a caulking tool will drive the lead back into its place, and make all tight again; and, even where the lead has not visibly started from its place, a little caulking

Defects in
waste-pipes.

Imperfect
joints.

will generally make a joint tight about which there is a suspicious odor.

Putty. Where it is impracticable to caulk thoroughly a joint in a cast-iron pipe which has been found to leak slightly, the householder need not hesitate to apply putty around it, over the lead. Although architects refuse to accept from a contractor any cast-iron waste-pipes which show putty in the joints, on account of the danger that the joint may have been made tight with putty, instead of the more permanent lead, there are many cases where the slight leaks which develop themselves, in course of time, in all lines of cast-iron pipe exposed to the variations of temperature in dwelling-houses, may be perfectly cured in this way; and the putty can be renewed as occasion may require. Only the very best putty should be used for such purposes, the mixture of marble dust and petroleum sold as cheap putty affording no security; and in basements and other places where rats are likely to get at the putty, it should be mixed with red lead, to prevent them from gnawing it away.

Air-pipes. If the joints of the soil-pipe are found to be tight, and no small "sand-holes" are discovered in the pipes or fittings, the air-pipes, which communicate freely with the soil-pipe, and are of the same material, and jointed in the same way, should be examined, and, if necessary, subjected to similar treatment.

By-pass. Occasionally, although not very often in modern

plumbing work, a dangerous leak of sewer-gas is caused by improper arrangement of pipes, forming a "by-pass." In Figure 25, suppose W to be a wash-basin, with an S trap, S, under it, and B to be a bath, with a round trap, T, under the floor. Both traps are back-vented by the air-pipes, A, A, connected into a main air-pipe, P. If the waste from the wash-basin is connected into the bath-waste beyond the trap, as it should be, no sewer-gas can escape either into the wash-basin or the bath, so long as the traps are full; but it sometimes happens that a careless or ignorant plumber, to save a little pipe, or give the job a neater appearance, will connect with the bath-waste inside the trap, T, as shown in the

figure, thus opening a free passage for the sewer-air which comes up the bath-waste, and is stopped by the water in the trap, T, through the two air-pipes and

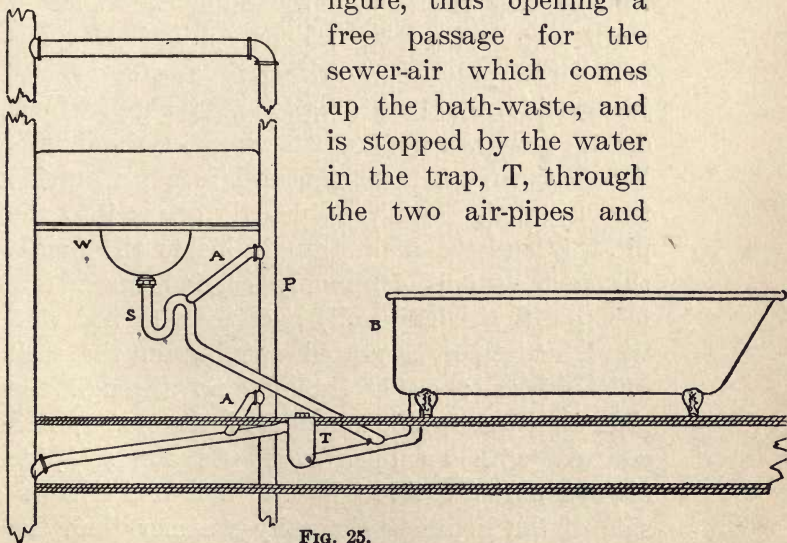

FIG. 25.

the basin-waste to the "house side" of the bath waste, through which it pours in a stream, entering the room by the waste and overflow of the bath. Such a defect as this is not generally shown by the water-test, as minor connections are made after the main pipes have been tested, but it may have very serious consequences; and, if a by-pass of this sort should be discovered, the waste and overflow openings through which it allows sewer-gas to escape should be securely plugged with corks, or covered with strong paper, pasted on, until a plumber can be called in to make the necessary changes in the pipes.

Foot vent.

If none of these defects are found to explain an unpleasant smell about the waste-pipes, the trouble may come from the outside. Where a main trap is used on a house-drain, it was formerly the practice to contrive a "foot vent," just inside the trap (Fig. 26), to supply fresh air to the system of waste-pipes in the house. Where the main trap is placed in a pit outside the house, the foot vent usually opens into the pit. Where the main trap is inside the house, the foot vent is commonly carried up a few feet on the cellar wall, and then turned outward, ending at a grated opening in the wall of the house; or is brought up through the ground, close to the outside of the house, and covered with an open cap. As the soil-pipe always extends through the roof, and the inside of the house is generally warmer than the

outside air, there is, at ordinary times, an upward current through the soil-pipe, and, in consequence, an inward draught at the foot vent; but the sudden discharge of any considerable quantity of water from one of the house fixtures temporarily reverses the current, the rush of water carrying the air with it, so that, for a moment, air comes out of the foot vent, instead of being

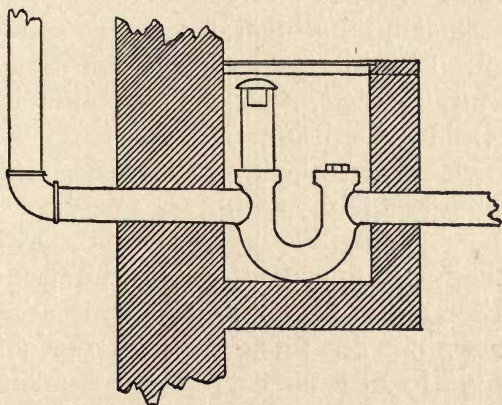

FIG. 26.

drawn in, and the air which comes out brings with it the odors of the drain. If there is a window near the opening of the foot vent, these odors are very likely to be unpleasantly perceived, particularly if the window belongs to a room constantly occupied.

In order to make sure whether this is the origin of the trouble, some one should be stationed at the foot-vent opening, while another discharges

a bath-tub or wash-tray in the house; the coincidence of an unpleasant smell at the foot vent with the discharge of the fixture in the house will be good evidence that this is the source of the annoyance. The best remedy for it would be to take out both the foot vent and the trap; but, if the official regulations do not permit this, the foot vent should be extended to some place where its occasional exhalations cannot reach a window.

Occasionally, the other end of the soil-pipe is at fault. The strong current which, with modern plumbing, usually ascends the pipe, diffuses itself to a considerable distance around its upper opening; and, in houses with steep roofs, and attic rooms, it often happens that the top of a soil-pipe is left open near a window. An inspection of the upper portion of the pipe will show what the conditions are in this respect; and, if necessary, the pipe may be extended to a greater height, supporting it by carrying it up beside a chimney or dormer. In some houses, particularly in cities, the rain-water conductors are connected with the soil-pipe, without a trap between, and, in such cases, bring a plentiful supply of drain-air to the dormer windows which happen to overlook the gutter. Where this is the case, the simplest remedy is to put a trap between the conductor and the soil-pipe, and this is generally required by law, where there are windows in the roof above the gutter. In houses with flat roofs, where there are no windows above the gutter, the trap

between the conductor and the soil-pipe is unnecessary, and is in some respects objectionable, as it is apt to fill with ice in winter.

Sometimes the smell of the drains will be carried into a house through a fireplace; and, where the smell is particularly noticeable near a fireplace in warm weather, this may be suspected. In summer, when the house is cool, and the outside air warm, it is very common, particularly in city houses, for the current in the flues to be reversed, the cool brickwork chilling the air in the flues until it is heavier than a column of outside air of the same section and height. When this occurs, the air in the flues will descend, bringing with it into the rooms the "sooty smell" characteristic of rooms in old houses which are kept shut up in hot weather; and the same current which conveys the fragrance of the soot in an old chimney brings also down the flue a portion of whatever vapors may be hanging at the time around the top of the chimney. Among these are often exhalations from the open top of a soil-pipe which is carried up beside the chimney; and the quantity of such exhalations is not unfrequently sufficient to make them very distinctly appreciable to people sitting or standing near a fireplace in communication with the flue. As the testing of the waste-pipes throws no light on a condition of this kind, its existence may be suspected in cases where mysterious smells have baffled the intelligence of the local plumber.

Testing with
peppermint.

When careful examination of the pipes and fixtures shows no visible leaks, or other means of communication between the air of the house and that of the drains, the pipes, if the smell which it is desired to investigate still continues, and cannot be traced to a dead rat, or mouse, or to bad eggs or scraps of meat in the ash-barrel, or to remains of glue-size left by painters or paperers, should be tested. This is thoroughly and scientifically done by engineers who make it a part of their professional work, or by the best plumbers; but the householder who has not a first-rate plumber within reach can easily make a satisfactory test for himself.

For this purpose two ounces of oil of peppermint should be procured. Druggists very generally keep oil of peppermint in two-ounce glass tubes, hermetically sealed, for plumbers' use; but, if those are not available, a well-corked bottle will answer. Armed with the oil of peppermint and a pail or pitcher of hot water, some one should be sent, if possible, to the roof, to pour the peppermint into the top of the soil-pipe; but, if it is impracticable to reach the top of the pipe, the oil may be poured into the highest sink, basin, or other fixture in the house, keeping the door of the room in which the fixture is placed tightly closed. The tube of oil is to be broken, or the bottle uncorked, and the contents poured into the soil-pipe, or the waste-pipe of the fixture, followed immediately by the

hot water. The warm water washes the oil down the pipe, at the same time that its heat volatilizes it, diffusing the vapor through the whole system of waste and air pipes; and, as soon as it is poured down, the opening through which it was poured should be tightly closed, by stuffing in paper or otherwise, to increase the thoroughness of the diffusion of the vapor, and prevent its escape. The person deputed to pour the peppermint into the pipes should not come into the house, or leave the room in which he operates, until the test is over, as he would bring so much of the perfume with him as to vitiate the test. Supposing care to have been taken in regard to this point, any smell of peppermint in the house will indicate a defect in the waste or air pipes near the place where the odor is perceived; and closer inspection will generally determine the exact location and character of the defect, which may, in many cases, be remedied by recaulking, or by the application of putty. Where a pipe is broken, or rusted through, the smell of peppermint will be so strong as to call immediate attention to the trouble, and, in such cases, the pipe must be renewed.

It is desirable, after such leaks as may be disclosed by the peppermint have been stopped, to repeat the test; and the householder may be sure that no sewer-gas can escape into his rooms from pipes which are tight enough to keep in the vapor of peppermint applied in this way.

Repetition
of test.

If, as is sometimes the case in large houses, or in those built some years ago, when plumbers had a mania for extending air-pipes through the roof, there is more than one pipe projecting above the roof, all such pipes, except the one into which the peppermint is to be poured, should be temporarily closed with wads of paper, to prevent the current which generally exists in house-pipes from drawing off the vapor before it has diffused itself through the entire system. As all the waste-pipes in the house, however numerous, join inside of the main trap, it is only necessary to pour the peppermint into one pipe to fill the whole system with the vapor; but the washing down of the oil with hot water is an essential feature of the test, as without it there is no certainty that enough vapor will be generated to fill all the pipes.

Soil-pipes
entering
flues.

In some houses, built when plumbers were less enlightened than they are now, or when inspection was less rigid, soil-pipes, instead of being carried up through the roof, may be found entered into a chimney-flue, often the range-flue, probably with some vague notion of ventilating the fixtures, just as, in modern plumbing, the local vent of a water-closet is connected with a heated flue. It is hardly necessary to say that the modern local vent has nothing to do with the drains, simply conducting the air of the room into the flue through the bowl of the water-closet; while the soil-pipe, on the other hand, being separated

from the water-closet basin by the sealing-water of the trap, can do absolutely nothing to ventilate the closet, and serves only to contain, and guide to a safe outlet, the air of the drain ; so that the only result of connecting a soil-pipe, or a back-vent pipe from a trap, with a chimney-flue is to saturate the porous brickwork of the chimney with foul odors, which soon diffuse themselves into the rooms through which the chimney passes. An objectionable arrangement of this kind often exists undiscovered in old houses, and may be suspected where a foul odor hangs persistently about rooms which have a chimney passing through them, but no pipes. The peppermint test may be used to confirm these suspicions, but, as the peppermint vapor penetrates the brickwork very slowly, repeated trials may be necessary.

Where the pipes are proved tight, the peppermint may show leaks around the fixtures. Most water-closets, for instance, which have the trap formed in the porcelain, including the siphon and washout patterns, as well as the all-porcelain short hopper and wash-down closets, make the connection between the outlet of the porcelain closet and the lead branch of the soil-pipe by means of a projection of the porcelain, which fits loosely into the lead pipe, the joint being filled with putty. In practice, the end of the lead pipe is brought up through a hole in the floor and “flanged out” around the opening ;

Leaks
around
fixtures.

and, after a mass of putty has been spread on the floor about the opening, the closet is set in place, the projection entering the mouth of the lead pipe, while the spreading porcelain foot covers the putty on the floor. The bolts which hold the closet to the floor are then put in and tightened until the putty is squeezed out to the edge of the foot, when it is trimmed off, and the setting is complete. In most cases this makes, at first, an air-tight setting; but if the closet is repeatedly taken up, to prevent it from freezing in winter, or if the floor should shrink materially, or the closet become displaced, a crevice may be opened in the putty, through which sewer-gas will pass directly from the soil-pipe. A leak of this kind is immediately exposed by the peppermint test, and is remedied without difficulty by unscrewing the bolts, and the coupling which connects the closet with the flush-pipe from the cistern, detaching the local vent, if there is any, by the slip-joint which is always used in connecting it, and taking up the closet, putting down fresh putty, or grafting-wax, which is preferable to putty for the purpose, and resetting and re-connecting the closet.

As a leak of this kind may exist for a long time before it is detected, to the injury of the health of the inhabitants of the house, closets with metal traps, which can be soldered permanently to the branch of the soil-pipe, are preferred by many architects. In this case the

detachable joint, by which the closet is removed and reset, when necessary, is between the porcelain bowl of the closet and the trap. If this joint should not be perfectly tight, which is frequently the case, water will leak through it from the closet-bowl on the floor; but, as the leak is on the house side of the water-seal of the trap, no sewer-gas can come through it so long as the water remains in the trap, and no harm will be done beyond the wetting of the floor. With certain forms of metallic-connection closets, however, a leak between the bowl and the metal trap may drain the water out of the trap, destroying the seal, and opening a passage for floods of sewer-gas; so that each form has certain advantages as well as disadvantages. Some expensive all-porcelain closets, instead of requiring putty for making the joint with the branch of the soil-pipe, have a provision for packing the connection with copper or lead gaskets; but there is room for further improvement in this direction.

After the persevering householder has investigated the cesspool, the foot vent, and the chimneys, applied the peppermint test, and repaired the leaks in pipes and fixtures, he may still be troubled by unpleasant smells, the cause of which his search has failed to disclose. These will generally be found on closer inspection to proceed from the overflow openings of wash-basins, baths, or pantry sinks. If these fixtures

Overflows.

have stand-pipe overflows, the trouble may easily be remedied by taking out the stand-pipes and cleaning them, with the recesses or tubes containing them, with a sponge or rag tied to a stick or stout wire, using ammonia or soda, if necessary, to dissolve and remove grease. If the fixtures, on the contrary, are of the old-fashioned type, the overflow may be inaccessible to a sponge, and it is in overflows of this sort that smells are most likely to occur, as the overflow-pipe in such cases is comparatively long, and, when lined with a mixture of old soap, hair, epithelium cells, and similar materials, is capable of giving off an aroma of astonishing power. Bath-tubs, which have a long and large overflow, seldom washed, except by the soapy scum of a hot bath, often become surprisingly offensive, particularly in hot weather; and wash-basins, especially in nursery bath-rooms, where milk occasionally gets into the overflow, may be hardly less so.

When a smell of this sort is traced to the grated opening of an inaccessible overflow which cannot be sponged out, a slow, but tolerably efficient cleansing can be given it by filling the fixture to overflowing with clean water, and allowing washing soda or ammonia to mix with the current as it passes through the strainer. In the case of nursery wash-basins or sinks in old houses, where the overflows are of lead, even this treatment may not be sufficient, as decomposing

milk seems to saturate a lead pipe beyond recovery ; and, under such circumstances, it may be necessary to cut out the lead overflow-pipe and substitute a fresh one, or put in a modern fixture with a stand-pipe, or an overflow formed in the porcelain.

Defects in supply-pipes commonly show themselves by leaks, which may assume all proportions. The worst leaks are, perhaps, those due to the splitting of unannealed brass pipes, which may deluge a house in a few moments ; but even unannealed brass pipe does not always split, while respectable plumbers generally use annealed pipe, so that accidents from this cause are rare. Iron pipes give much more annoyance by filling up with rust. With some waters a badly coated or defective iron pipe, even if enamelled or galvanized, may choke completely with rust in a month, while the best galvanized pipes sometimes serve perfectly for many years ; but there is always a chance of trouble with iron supply-pipes of any kind. Where they are exposed to freezing, also, iron pipes should be avoided, as the freezing of such a pipe generally splits it for nearly its whole length, causing a destructive leak when it thaws again, while a lead pipe, in freezing, bulges locally, opening at most a small hole, which does not give passage to much water on thawing, and can be closed by a drop of solder.

Defects in
supply-
pipes.

Both iron and brass pipes must be put up with care to allow for expansion, by arranging

long, right-angled turns in them, which can spring a little if necessary. Without this precaution the contraction of a long, straight line of such pipe strains the joints, and soon causes leakage. Lead pipes are not liable to leaks from this cause, as the metal is soft enough to yield under the strain; but, if improperly put up, with iron hooks instead of wide and smooth brass bands, or hard-metal "tacks" soldered to the pipes, the alternate expansion and contraction of the pipe as it passes over the hooks causes these to cut into the soft lead, so that in course of years they may be cut so nearly through as to be unable to resist the pressure of the water in them, and a bad leak is the result.

Water-
hammer.

The softness of lead exposes pipes made of it to another danger, from the so-called "water-hammer." It is a familiar property of water that, being practically incompressible, it transmits through its whole substance with undiminished force a blow struck anywhere upon it. Where the water-supply of a house is under a high pressure, the sudden closing of a faucet to shut off a flowing stream operates as a blow upon the water, the force of which is transmitted through the entire system of cold-water pipes, causing the concussion so familiar to housekeepers. As the concussion acts through all portions of the system, it produces most effect at the weakest part; and, where it has not been properly guarded against, some pipe, often remote from

the faucet to which the trouble is due, will begin to swell from the internal pressure. As soon as it begins to yield, the force of the water-hammer, acting on a larger surface, increases its effect, and the bulge enlarges until the pipe bursts. This is a less common accident now than it was in former times, as the compression-faucets at present generally used shut off the water much more gradually than the old-fashioned ground-cocks; but it still sometimes occurs, particularly where self-closing cocks are used, and the way to avoid it, or to prevent its repetition, is to arrange "air-chambers," or extensions of the supply-pipes, generally over or near the faucets in the lower stories of the house, where the pressure is greatest. These air-chambers are simply extra lengths of pipe, closed at the end, and usually turned upward. They are full of imprisoned air, which cannot escape at the bottom against the pressure of the water, or at the top, this being closed, and therefore remains, like an elastic cushion, ready to receive and absorb the shocks transmitted to it through the water. To be of much use, such air-chambers should be eighteen inches or two feet long; but, if of proper size, they act very efficiently to reduce water-hammer, so long as any air remains in them. Under heavy pressures, however, the air in them is gradually dissolved in the water until they are completely filled with water, and their action as air-cushions ceases. The water-hammer then reappears; but, in order

Air-
chambers.

to restore the efficacy of the air-chambers, it is only necessary to shut the water off at the stop-cock always provided just inside the cellar wall, and let the house-pipes drain out through the waste-tube of the stop-cock. On opening the stop-cock again so as to let the water into the house-pipes, the air-chambers will be found filled with air, ready for renewed usefulness.

Faucets.

Ground-cocks.

Where the supply-pipes are intact, the faucets may drip, or leak more copiously, wasting water in an annoying way. The old-fashioned "ground-cocks," still extensively used, contain a tapering

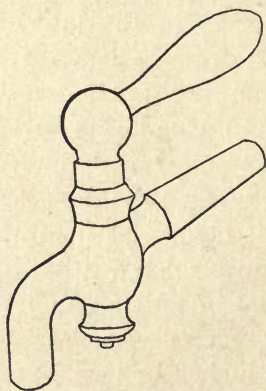

FIG. 27.

brass plug, with a hole through it (Fig. 27) which can be turned to coincide with the bore of the faucet, or at any angle with it, either by a handle attached to the top of the plug, or, in the case of "swing basin-cocks," by swinging the faucet itself, the plug remaining stationary. In either case, particles of sand in the water

soon cut grooves around the plug and its seating, through which water finds its way, causing a dripping which is practically incurable.

Compression-cocks.

As the leakage of a ground-cock can be remedied only by putting in a new faucet, most modern houses are fitted with "compression-cocks,"

which are made on a different principle (Fig. 28), the flow of water through them being checked by pressing a spindle, armed with a leather or rubber washer, upon the end of a tube, through which the water passes on its way to the outlet of the faucet. The pressure is usually applied by screwing down the spindle, by

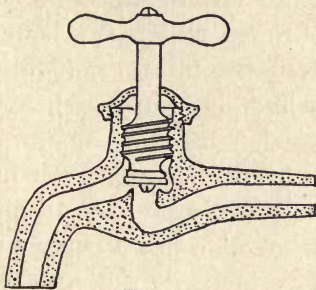

FIG. 28.

means of a handle at the top; but a variety is often used in which a lever takes the place of the screw. The washer is attached to the end of the spindle by a short, brass screw, passing through a hole in the washer, and it is the work of a few moments only to take off a washer and replace it by a new one. This is an operation frequently necessary, as the washers wear rapidly, especially where exposed to hot water. The first step in the process is to shut off the water temporarily from the faucet to be operated upon. This is not absolutely necessary, as, in case of emergency, a worn washer may be replaced without shutting off the water; but, as the water spouts in streams through the top of the faucet during the operation, it is more comfortable for the operator to have it shut off.

Putting on
new
washers.

Where the patient is a hot-water faucet, as is most commonly the case, the easiest way to shut

Shutting off
the hot
water.

off the water, where the hot-water system is supplied from a tank in the attic, is generally to close the opening in the bottom of the tank, through which the water descends to the boiler. Usually, this is controlled by a "cistern-valve," which is simply a heavy weight, with a leather washer on the bottom, and a guide to direct its movement, which can be dropped upon the end of the descending pipe. In most cases the cistern-valve has a copper wire attached to it, with two loops at the end, which can be hooked over a nail, or screw, somewhere at the top of the tank, to keep the wire from falling into the tank. When the hot-water system is in operation, the wire is hung by the lower loop, which holds the cistern-valve up, away from the mouth of the pipe; and, to close the latter, the wire is simply unhooked, the valve dropped, and the wire again hung by the upper loop, to prevent it from being lost in the water.

Occasionally, where the tank is placed above the ceiling, or overhead in a bath-room, the valve in the cistern is suspended from a lever, from the other end of which a wire is carried down to some accessible point on the wall of the room, and attached to a hook, generally sliding on a brass plate, with a catch at the bottom. When the hook is drawn down until it catches, the valve is opened; and, to shut the water off, it is only necessary to disengage it and leave it free.

Still more rarely, the tank is either raised above

the floor, or supported near or above the ceiling, with either an ordinary stop-cock or a steam-valve on the descending pipe under the tank, which can be opened or closed in the same manner.

However the pipe descending from the tank may be closed, the water in the hot-water system will be held temporarily suspended, by atmospheric pressure, until it is opened again. If there is an expansion-pipe to the system, the suspension will not be complete unless this pipe, which is usually bent down over the overflow of the tank, is plugged with a cork, or a bit of paper; but the operation of putting in a new washer is not interfered with by a little leakage of water.

When a cold-water faucet needs a new washer it is necessary to shut off the cold-water supply, either just inside the cellar wall, where a main stop-cock is always provided, or, if a special shut-off is arranged for the fixture requiring attention, this may be closed. In either case, there will probably be a temporary spouting of water from the waste-tube of the shut-off cock, which may need to be attended to.

When the water has been shut off, the first step in the operation of replacing the washer is, with most compression-cocks, to unscrew the octagonal cap through which the stem of the spindle passes, and which is furnished with packing, to prevent leakage around the stem. A wrench is likely to be needed for unscrewing this cap for the first time, but it is not necessary to screw it

Putting on
new
washers.

down tight in replacing it. After the cap has been loosened, the spindle is easily unscrewed and taken out, bringing the cap with it. The washer, or its remains, will then be seen, held to the bottom of the spindle by a round-headed brass screw. Supposing the careful householder to have provided himself with a few half-inch washers for basin-cocks, and five-eighths inch for sink, bath, and wash-tray cocks, which can be had of any dealer in plumbing materials, there is nothing more to be done but to take out the round-headed screw, remove the old washer, put on the new one, replace everything as before, and turn on the water again.

The whole operation, including turning the water off and on, can easily be performed in five minutes, in most houses; and, as a plumber and his helper often consume half a day in coming from the shop to see what is wanted, going back to the shop for the necessary tools, returning to the house, making an elaborate search for the shut-offs, applying the new washer, refreshing themselves with a pipe after their exertions, and getting back to the shop again, there is a material economy in employing home talent in an operation which is required several times in the course of a year, even in a small house. Plumbers generally use washers of thick leather for cold-water faucets, and special washers of various materials, including pasteboard and hard rubber, for hot water, which soon softens and disintegrates leather; but, if the householder can apply washers for himself,

leather will answer for all purposes, and is less likely to crush and injure the thin, brass edge on which the washer presses than the harder materials. In any case, this thin edge, under the action of hot water, slowly crystallizes and crumbles away, until it becomes so uneven that even a leather washer will not keep the water back. When this happens, the faucet is practically worthless, and a new one should be put in its place.

Ball-cocks are only used to supply tanks or cisterns of some kind; the ball, or float, rising as the cistern fills, so as to shut off the water when the cistern is full. As not only the main tank, but all the water-closet cisterns, and often the furnace-supply, are provided with ball-cocks, the number of them in a house may be considerable, and they are quite likely to give trouble. In substance, they are usually simple compression-cocks, turned over on their side; the float, with the brass rod which connects it with the spindle of the cock, taking the place of a handle. As the float is almost constantly in motion upward or downward, as the cistern is discharged and refilled, the washer wears out slowly, allowing the ball-cock to leak; and leaks also occur from other causes. As all tanks and cisterns supplied through ball-cocks are provided with some sort of overflow, the water which leaks through the ball-cock runs off, almost unnoticed, through the overflow, which generally discharges, either directly or indirectly, into a

Ball-cocks.

water-closet basin, escaping through the trap, without doing any visible harm; but, as a great deal of water may be wasted in this way, to the unpleasant surprise of householders who take water through a meter, such leaks should be promptly stopped.

A very common source of waste of water in this way is not strictly leakage of the ball-cock, but the bending of the rod which carries the

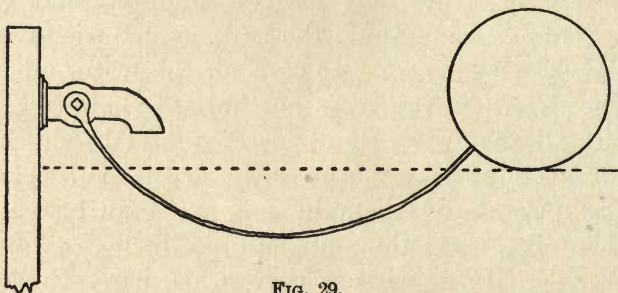

float. This rod is often made of light tubing, instead of solid wire, and is rarely stiff enough to resist firmly the powerful upward pressure of the water on the float; so that it by slow degrees acquires an upward curve (Fig. 29). It is obvious that if a ball-cock with a straight rod is arranged so as to shut off the water when the float reaches a certain height, the consequence of the upward bending of the rod will be that the float must be lifted higher to produce the same effect in shutting off the water; and, as the bending increases, the water ultimately reaches

the level of the overflow before it is shut off. Inspection of the ball-cock and cistern will generally show whether such curvature of the rod has taken place, and, if so, it can, with care, be bent back again to its proper position, in which it will stay for a longer or shorter time, according to circumstances.

If the rod connecting the float with the ball-cock is found to be straight, but the cistern overflows, this is probably due either to the wearing out of the washer, or to the presence of some foreign substance between the washer and its seat. The latter is very apt to occur in a new house, as the particles of lead cut or rasped from the pipes are often carried along by the water, and are caught under the washers. In either case the trouble is easily remedied by shutting off the water, taking off the rod, which is usually held in place on the spindle of the ball-cock by a cap screwed over it, and removing the spindle which carries the washer, cleaning or replacing this as may be necessary.

If, on inspecting the cistern, the float is found submerged, the cock running a full stream meanwhile, the ball itself probably leaks, so that it floats no longer, and the hole, after draining out the water, should be found and stopped with a drop of solder. Nearly all floats are made of copper, which is easily repaired in this way.

Temporarily, in this case, as in that of the bending of the rod, the overflow can be stopped

by tying up the ball to something overhead. It is usual to provide all ball-cocks with a chain anchored to some fixed point, which will prevent the ball from falling to a position in which the rod hangs vertically down. If this precaution is neglected, it may happen, when a cistern or tank is emptied, and then refilled, that, in refilling, the upward pressure on the float will be exerted directly in the axis of the rod, pushing this upward, but not turning it to its proper position, so that the cock remains open to its fullest extent, wasting a large amount of water. A touch with the hand will bring the float up to its place in such cases, but it should be provided with some means of preventing it from assuming such a position again.

Condensa-
tion.

Housekeepers are often alarmed in summer by a dripping of water from pipes, due solely to the condensation of moisture from the atmosphere upon them when they are chilled by the passage of cold water through them. In kitchens and cellars, particularly where the atmosphere is moist, the course of the cold-water supply-pipes may often be traced by the water which drips from them on the floor. A little observation will show the difference between the dripping of condensed water, which forms in drops all over the surface of a cold pipe, and the tiny stream which issues from a cracked pipe or imperfect joint; and, if the condensation is annoying, it can easily be checked by wrap-

ping the offending pipe with asbestos paper or felt.

Plumbing fixtures are not very liable to defects not connected with their waste-pipes and traps, or their supply-system, but the defects which sometimes occur in them are not easily curable. All manufactures of white earthenware, including kitchen sinks, pantry sinks, laundry wash-trays, bath-tubs, water-closets, and wash-basins are liable to "craze," the glaze cracking, so as to injure the appearance of the fixture, and sometimes coming off in chips, or flakes, leaving the body of the earthenware exposed. As this is somewhat porous, it soon becomes discolored and looks badly, although the use of the fixture is not seriously interfered with. "Crazing" is much less common now than it was before the American potteries brought the art of manufacturing plumbers' earthenware to its present perfection, but it still occurs to some extent. For wash-basins and water-closets it can be entirely avoided by using, instead of ordinary glazed earthenware, the "vitreous china," also an American invention, which differs from glazed earthenware just as French china or porcelain differs from ordinary stoneware, being far stronger and handsomer, while its glossy surface is unaffected by anything which does not destroy the article itself. Unfortunately, sinks, bath-tubs, and wash-trays are too large to be made of vitreous china; and, although

Defects in fixtures.

Vitreous china.

they sometimes profess to be of "porcelain," or of "vitrified" ware, they are, unless in very exceptional cases, simply of earthenware.

Another reason for preferring vitreous china to ordinary earthenware, particularly for water-closets, is that the latter, being of somewhat complicated form, are always moulded in several pieces, which are stuck together, when the clay is soft, and then hardened by burning, the glaze being subsequently applied, and fixed by a second burning. As the burning is effected at a far lower temperature than that required for making vitreous china, the different portions of the earthenware fixture do not always unite perfectly; and there are few accidents more annoying than the sudden separation of a water-closet bowl into its component parts while in daily use.

For kitchen sinks a dark-colored ware is sometimes used, made of a clay similar to that employed for manufacturing drain-pipes, and glazed in the same way, by throwing salt into the fire in which it is burned. These sinks are cheap, and are said to be strong and durable, but they are not attractive in appearance. A yellow ware, like that used for the pie plates and pudding bowls which have ornamented American pantries for a century, is also occasionally used for sinks, but with no conspicuous advantage.

All fixtures of "porcelain," glazed earthenware, and vitreous china are divided by the

manufacturers, before they are sent out, into three grades, known as "A," "B," and "C," those of the "A" grade being supposed to be as perfect as the process of manufacture will admit; those of the "B" grade being slightly warped, or having imperfections in the glaze; while those of the "C" grade are more warped, or have greater imperfections in the glaze. All the grades, however, are suitable for use, the differences being only in appearance.

"A," "B,"
and "C"
qualities.

The enamelled iron now so much used for bath-tubs, and to a certain extent for wash-basins, sinks, and other fixtures, is somewhat liable to chipping of the enamel. As with earthenware, the manufacture of enamelled iron has been brought to great perfection in this country, and bath-tubs with certain trade-names are guaranteed by the makers, who will furnish a new one in place of any tub of the guaranteed names from which the enamel begins to chip within two years after it is put in. Any plumber can furnish a list of the guaranteed varieties of tub, which change from year to year; but the makers do not always remember to include in their guarantee the cost of the plumber's labor in taking out the old tub, and putting in the new one; and nothing is guaranteed in regard to tubs whose trade-names do not appear on the list. The cracking of the enamel of any enamelled-iron fixture is followed by the rusting of the iron, and consequent unpleasant staining; so that, although the risk is

Enamelled
iron.

not very great, and the best enamelled work is beautifully smooth and clean, fixtures of this kind, apart from bath-tubs, are not so much used in dwelling-houses as they perhaps deserve to be.

Soapstone
and slate.

Soapstone and slate are much used for kitchen sinks and wash-trays, and retain their favor among housekeepers, notwithstanding the competition of the whiter and more beautiful earthenware and enamelled iron. For wash-trays, particularly, soapstone and slate have the great advantage that the back and front of a set of three or four trays can be made in one piece, the trays being simply divided by partitions. The clothes can thus be drawn over from one tray to another without the dripping on the floor between them, incident to the use of the separate trays of earthenware or enamelled iron; while most clothes-wringers are fitted for slate or soapstone trays, although they can be had for the other varieties. Both slate and soapstone are, however, liable to defects, some of which might be avoided by greater care in the selection of the material. Most modern soapstone, for example, is acted upon by water, which corrodes the surface into pits, and finally destroys it; while the edges of the stone easily crumble away. Slate is much harder than soapstone, and would be superior as a material, if it were not for its liability to crack. As many varieties of slate are of immense strength, it should be easy to select a material not subject to cracking; but the manufacturers have not yet

seen fit to do so, and, as a crack across the bottom of a sink, or a set of wash-trays, is a serious matter, slate is less popular than it might otherwise be.

Whether slate or soapstone is used for kitchen sinks or wash-trays, it should be well oiled with linseed oil before being put into use. Either stone, when dry, will absorb a considerable quantity of oil, which fills the pores, prevents, to a great degree, the corroding action of water, and, by darkening the stone, prevents it from acquiring the greasy look common to such fixtures.

Although unsuitable for wash-trays, on account of the danger of staining the clothes, iron is, perhaps, the best, as well as the cheapest material for kitchen sinks. Such sinks should be of cast iron, which is far less liable to rust out than the thin sheet steel sometimes used. Sinks are usually sold galvanized, and the galvanizing protects them for a time, but the acids used in cooking soon remove the coating, so that it is not of great advantage; and the bare iron, which soon becomes covered with a thin film of grease, answers very well, and can be freshened at any time with a little black paint. The weak point about iron sinks is that, being cheap, the manufacturers have not taken the trouble to make them with the roll rims and high backs which add so much to the neatness and convenience of the enamelled and porcelain sinks; so that it is necessary, to avoid splattering the wall behind them, to cover it with sheet copper, sheathing, or tiles.

Iron sinks.

Wash-
basins.

Wash-basins often give trouble by dripping or overflowing, even if they are not broken by dropping tumblers into them, which is a very common occurrence. The waste-pipe is usually connected with the bottom of the basin by a brass coupling, made tight with a leather washer, and if this coupling is not properly screwed up, or if the washer is defective, the basin will drip. The supply-pipes, also, are usually connected by similar couplings to the faucets, and often leak, through want of care in screwing them up. The overflow of a wash-basin, also, is rarely capable of carrying off all the water that the two faucets, or even one of them, can pour into it, and a faucet left open soon causes the water to overflow over the edges of the basin. Where the basin is covered with marble, the upper edge, which, as it comes from the pottery, is uneven, is usually ground flat on a millstone, and the joint between it and the marble is filled with plaster of Paris; but even this only delays overflowing until the water reaches the top of the marble. Care is, of course, the only means of avoiding this trouble.

The plaster joint between the marble and the top of the basin soon washes out by the dissolving action of the water, leaving an unsightly open seam, which is often increased in size by the weight of the basin, and the waste-pipes attached to it, which tend to drag it away from the marble. The usual way of attaching a wash-basin

to its marble top is by means of three triangular brass "basin-clamps," fastened with little bolts, fixed in the under side of the marble. These do not afford a very firm support, at best; and as the separation of the basin from the marble allows water to splash over the edge, when the basin is in use, to fall on the floor, it is desirable to keep them well screwed up, and to fill the joint occasionally with fresh plaster of Paris.

The marble top of a wash-basin should be an inch and a quarter thick, or, at least, an inch and an eighth. This admits of proper "dishing" around the basin, so that spattered water will run into the latter, instead of falling on the floor. With a slab seven-eighths of an inch thick, such as is sometimes seen, the dishing is too shallow to be of much use, and the slab is fragile.

Marble
slabs.

The proper material for wash-basin slabs is what is known in the trade as "blue-veined Italian marble," being the product of the quarries of the Carrara region. This, although oil or ink will stain it slightly, is nearly non-absorbent; while the white or veined American marbles, sometimes substituted for it by designing contractors, soon become dingy, even colored soap being often sufficient to stain them.

Water-closets, especially of the siphon-jet type, are often defective, cracks occurring in burning which allow water to escape. Those made of vitreous china are much less liable than the cheaper earthenware ones to this trouble, and

Water-
closets.

closets of the best class are alleged to be tested before they are sent out; but no tests beyond a hasty glance are applied to the cheaper ones. The dealer who sells the closet will generally replace a leaky one by a new one, but there is a plumber's bill to pay for labor in making the change, which he does not usually feel called upon to assume.

Besides possible defects in the closet itself, the coupling connecting the supply-pipe to the flushing-rim often leaks, particularly when the closet has not been used for some time, and the leather washer of the coupling has become dry. The washer may, when the closet is used again, swell and become tight; but, if not, the coupling may be screwed up a little. In a similar way, the leather washer by which the connection between a short hopper and a lead trap under it is made tight often dries, so that, when the closet is used, water escapes upon the floor. The remedy for this trouble is to tighten the clamps by which the hopper and the trap are held together.

The overhead cistern of a water-closet often needs attention. If the ball-cock does not close properly, the water will overflow constantly into the bowl of the closet, and the ball-cock should be treated as described under the head of Supply-Pipes. It often happens, also, that a bit of lead, or mortar, or other obstruction, gets under the cistern-valve, preventing it from being dropped into place, so as to shut the water off; or it may

be shaken out of place by a sudden jerk of the chain or rod, so that the water runs out of the bottom of the cistern into the bowl of the closet, the ball-cock of the cistern, meanwhile, pouring in a fresh supply. In this case, a moment's inspection of the cistern, or the simple pulling of the chain, followed by a slow and steady release, will often put matters right again, by enabling the cistern-valve to descend properly.

A few observations on the care of plumbing apparatus may close what is necessarily a long chapter. Naturally, the most dreaded enemy of all plumbing apparatus is frost, which will quickly destroy pipes and fixtures. Lead pipes suffer less from freezing than those of iron or brass, as they yield and bulge, opening only minute holes or cracks, instead of splitting. Pipes, both for hot and cold water, extending into rooms exposed to the cold, should have shut-offs, so that the water may be cut off, and the pipes drained, in cold nights; and pipes exposed to cold currents of air may with great advantage be protected by wrapping with hair felt, covered with stout cotton cloth, sewed on, as the felt without such protection is soon destroyed by moths. It should be remembered also that the space under the floors of an ordinary house is cold. Often, in winter, a thermometer let down through a hole in the floor into the space beneath will sink to a point thirty degrees or more below the temperature of the room, and where supply-pipes

The care of
plumbing
apparatus.

are run between the floor-beams they should always be protected. Such pipes must be laid on boards, firmly supported between the beams, and inclining a little, so that the water will drain out of them to whatever shut-offs may be provided. If this is not done, they will soon sag from expansion so that they cannot be drained, and will inevitably freeze and burst if left in cold weather. The wrapping of hair felt, or the more expensive magnesia covering, form the best protection for pipes in floors, but they are often buried in planing-mill chips, sawdust, or mineral wool, any of which will check the circulation of air around them, giving a certain protection.

On very cold nights, it is sometimes advantageous to reflect that lead, iron, and brass, but particularly lead, are good conductors of heat, and that the warmth from a lamp, set at some accessible place under a pipe, may be conducted many feet along the pipe to some inaccessible and exposed place, which will thereby be protected. For this reason careful architects sometimes arrange to have all the supply-pipes in a house pass at some point in their course through the kitchen, the heat from which is thus more or less disseminated throughout the system.

Another important circumstance is that hot-water pipes are usually the first to freeze. Of course, a pipe with an active circulation of hot water through it would not easily freeze, but there is rarely such a circulation in a house hot-

water system, and the branches from the main system contain water which is usually cold; and this water, having had the air expelled from it by heating in the water-front of the range, has lost a powerful protection against freezing. Most plumbers believe that if a pail of boiling water, and one of cold water, are set out of doors on a cold day, the boiling water will freeze first; and, although this idea is not, perhaps, scientifically accurate, it expresses what plumbers find to be the relative effect of cold on hot and cold water pipes.

If the pipes are found to be frozen on a cold morning, all rash measures should be avoided. With lead pipes, a slight bulge will generally show the location of the trouble, and examination should be made to see whether the pipe has burst. If no hole or crack can be discovered, preparations may safely be made for thawing it out. This process ordinarily consists in soaking cloths in hot water, and applying them to the affected spot; but equally good results can be obtained, with much less trouble, by setting a lamp, or an oil stove, near or under any part of the frozen pipe, trusting to conduction to carry the heat to the place where it is needed. If not even a bulged place can be found, the freezing is not likely to be serious, and may be treated by simply warming the room with an oil stove, or in any other convenient way. The washers of compression-cocks often freeze to their seats on a

Frozen
pipes.

cold morning, and are readily released in this manner.

If a hole or crack is found in a frozen pipe, the water should be shut off from that pipe, or, on the thawing of the ice, the room may be deluged ; and the plumber may then be sent for to mend the pipe with a few drops of solder, or by putting in a new one, as the case may require. It is by no means a difficult matter for an amateur, in case of need, to scrape clean the surface of a lead or brass pipe around a small leak, and apply solder, with the aid of a copper "soldering-bolt," fitted with a wooden handle, and heated red hot in the kitchen stove, or even with a red-hot poker ; but the water must be shut off from the ailing pipe, and the ice thawed, or the steam produced by the contact of the hot solder with the ice or water will blow the solder away, perhaps to the injury of the operator. The solder will stick to a lead pipe without any preparation except scraping the lead ; but, when brass pipes are treated, it is necessary, after scraping the brass, to heat the pipe about the leak, by rubbing it with the hot soldering copper, and then apply a little solution of chloride of zinc, otherwise known as "soldering-fluid," or rub over the place, while hot, with a "soldering-stick," composed of rosin, wax, and other ingredients, which can be obtained of any dealer in electricians' supplies. After this, by rubbing on some melted solder with the hot copper, it can generally be made to adhere.

If, as occasionally happens, the water in the brass pipes connecting the water-front of the range with the copper bath-boiler, or the water in the bath-boiler itself, or in the pipes rising from the top of it, should freeze, great care should be taken in making a fire in the range. Even a small fire will make the water in the water-front boil if there is no circulation to keep down the temperature; and the boiling of the water, when the escape of steam is prevented by ice in the pipes or boiler, is very dangerous. It is always safest to maintain a fire in the range through very cold nights, so as to keep the water warm and in circulation; but, if this precaution is neglected, and water, after a cold night, will not flow from the sediment cock usually placed on the lower pipe connecting the boiler and the water-front, no fire should be made in the range until the pipes have been thawed out, by a lamp or otherwise, so that water will run from the sediment cock; and, even then, the fire should be small, and closely watched, until the upper part of the boiler is hot to the hand, showing that it is filled with warm water, which will soon make its way through the pipes above.

In the present age of open plumbing, the housekeeper's cares are materially increased by the multiplicity of exposed pipes, traps, and other metal-work which must be kept in order. In old houses, the supply and waste pipes are still

The care of pipes.

covered by wooden casings, but these casings, enclosing a warm, dark, and moist space, form the favorite shelter of spiders and water-bugs, and the modern system of having everything exposed is much to be preferred. Usually, the faucets and supply-pipes, with the traps, waste and air pipes above the floor, in bath-rooms, are nickel-plated, as are also the towel-racks, sponge-baskets, soap-trays, mirror-frames, and other bath-room adjuncts which look so pretty in the dealer's show-room. If all these nickel-plated objects are wiped two or three times a week, they can be kept bright for years; but, if neglected, they soon grow dull, and ultimately become covered with a repulsive greenish gray oxide, which cannot be removed without taking the plating with it, leaving the copper or brass exposed. Many devices are current for meeting this difficulty. In very costly houses the faucets, pipes, and traps are sometimes plated with gold, at an enormous expense; and silver-plating is also employed, at much less expense, but without great advantage, as the silver tarnishes by exposure to gas and bath-room vapors, and the rubbing necessary to keep it bright soon wears off the plating, which is softer than a plating of nickel. Silver-plating is, however, desirable for the plugs and chains of laundry wash-trays, as the nickel commonly used soon corrodes, and stains the clothes, left soaking in the trays, with a green color; while silver, even if tarnished, will not stain anything in contact with it.

Next, perhaps, to gold-plating, the most costly, as well as most beautiful treatment for pipes and other bath-room metal-work consists in a coating of ivory-white celluloid enamel, which is applied also to the seats and covers of water-closets if desired. By painting the wooden cistern overhead of the same color, everything in the bath-room may be white and shining, giving a very pretty effect. Attempts have been made to obtain somewhat similar results by coating pipes and traps with a vitreous enamel similar to that used for bath-tubs, but they have not yet been very successful.

On account of the difficulty of keeping nickel-plating bright, and the cost of satisfactory substitutes, houses are occasionally fitted with pipes and traps of plain brass, which must, of course, be frequently polished, but is bright and attractive when kept in good order. A better material for the purpose is German silver, or one of the white metals made by the manufacturers of plumbers' brass goods. Although these white metals tarnish, they do so slowly, and when kept bright their appearance is better than that of brass.

Where it is not desirable to make a large addition to the ordinary cost of plumbing, a good and durable effect can be obtained by covering lead, brass, or iron pipes with aluminum bronze, the faucets, and other parts which are readily accessible for cleaning, being nickel-plated. The silver lustre of the aluminum bronze is liable

to little change, and the coating is easily renewed, while the combination of the dead-bronze finish with the shining nickel-plating is very agreeable.

Replating.

All plated work can be replated when the coating is worn off, or attacked by acids, which quickly affect nickel, and the second plating is said to be closer and harder, and therefore more durable, than the first. Occasionally a copper pantry sink is retinned, but the new coating of tin cannot be planished like the old one, and the effect is not very satisfactory. Tinned-copper bath-tubs are too large for recoating, and the common mode of improving their appearance is to paint them inside with "bath-tub enamel," or some other white paint mixed with varnish. The result is, however, rarely very satisfactory, as, unless the copper is thoroughly cleaned of grease by rubbing it with a rag dipped in a strong solution of soda, the enamel paint will come off in patches.

Earthen-ware.

The earthenware of plumbing appliances, if of good quality, is not very liable to deterioration. In towns where the public water-pipes are of wrought iron, or where the house-pipes, if of iron, have lost their coating of zinc or enamel, the porcelain, where most exposed to the flow of water, gradually acquires a brown stain; but, when this becomes unpleasantly conspicuous, it can generally be removed by washing with a solution of oxalic acid in water.

It is very often necessary to leave plumbing to itself for long periods, while the house in which it is situated is closed, and special precautions are necessary to protect the fixtures, either from destruction by frost in winter, or from losing by evaporation, in summer, the seal of water in the traps which forms the only barrier against the escape of sewer-air into the rooms.

The protection of plumbing in empty houses.

When the house is to be left to itself in winter, it is absolutely necessary, in the climate of any part of America north of Florida, or east of the California ranges, to remove water entirely from the supply-pipes. This is done by shutting the main stop-and-waste cock, always placed just inside the cellar wall, usually in a little pit, with a sand bottom, where it will be safer from freezing, and where the water which escapes from the waste-tube will be absorbed by the soil. This water, which often spouts out in a copious stream, when the shut-off is closed, comes from the house-pipes, the stop-cock being so arranged that, after communication with the street main is closed, a passage is opened to drain off the water standing in the house-pipes, which could not otherwise be removed, and would freeze if it were left undisturbed. After closing the main shut-off, and draining away such water as will flow through its waste-tube, all the faucets in the house should be opened, not forgetting the sill-cock on the outside of the house, so as to allow the water in the short

lengths of pipe leading to them to run out, as well as to admit air, and release the column of water which might otherwise be held in the main vertical pipes by atmospheric pressure; and the cistern-valves supplying the water-closets should be held open, by means of the chain or rod, until all the water in the cisterns has run out through the closet basin.

The copper bath-boiler, and the water-front of the range, must next be emptied together, by opening the "sediment cock," which will be found either at the bottom of the boiler, or on the lower brass pipe connecting the boiler with the range, remembering first to set a pail underneath if the sediment cock discharges, as is often the case, on the kitchen floor. A glance should then be given at the tank in the attic, to make sure that all the water in it has run out through the boiler that it supplies; and wash-trays, wash-boilers, pantry sinks, bath-tubs, and basins may with advantage be examined, to make sure that no water is left in them. If the pipes are properly laid, with no sags or depressions in them which cannot be drained, these proceedings will effectually clear them of water. If there is a water-meter in the house, however, it must be removed by the proper authorities; and if the house is to be left for several months, it is safest to have the water shut off at the official stop-cock in the street, as there may be a possibility that the pipe, unless this is done, will

freeze and burst between the cellar wall and the main shut-off, flooding the house as soon as it thaws again, and perhaps doing immense damage.

If any depressions are found, or are known to exist, in the supply-pipes, which cannot be drained, either through some faucet, or back through the waste-tube of the main shut-off, they should have holes bored in them at the lowest point; and, after the water in them has run out, the holes may be closed with a drop of solder, or a small brass "pet-cock" may be screwed in, which will serve at any time for draining the depression.

After the supply-pipes are thus cleared of water, the traps remain to be similarly treated. Sinks, pantry sinks, baths, and wash-trays usually have round traps, with a large brass cover screwed into the top, which can be unscrewed with a wrench, applied to the projection formed for the purpose on top. The water standing in the trap can then be dipped out, or removed with a sponge, and the trap-screw replaced. In some cases, round traps have the trap-screw in the side; and, as the removal or loosening of a trap-screw in this position allows the water to run out of the trap, a pail or tin pan should be put underneath, to catch the water, before the wrench is applied, or the ceiling below may be spoiled. With S traps, such as are commonly used under wash-basins, and sometimes under

baths, the same precaution is necessary, and it is required also with most of the patent traps, which generally open by means of caps below the water line.

After all the traps which have screws or caps have been opened, sponged out, and the caps replaced, the water-closet traps, which have no trap-screw, must be cleared of water by means of a sponge tied to a stick or wire. With most closets, it is easy to see when all the water has been removed, the trap being directly under the basin; but in closets of the "washout," or "Brighton" class the trap is concealed. Some patterns of washout closets have a removable cover over the trap, by means of which the trap is easily reached and cleared of water; but, where no such cover is provided, the trap may still be reached with a sponge attached to a bent wire, pushed down through the outlet by which the water escapes from the basin, and trial will show when all the water is removed. In closets of a still older type, like the "Jennings," or the "Demarest," with side outlets, the trap, if any exists, may be reached by unscrewing the plate through which the handle works, and lifting out the plug.

With closets of the siphon-jet pattern a little water remains, after the trap has been cleared, in the jet-tube. There is not usually more than half a teacupful; but, as this is quite enough to destroy the closet, if it should freeze, it must

be removed, either by opening a little screw inserted by some makers in the outside of the closet, near the bottom, or by means of a small sponge, tied on a wire, inserted through the jet opening. This operation, although rather tedious, is easier and safer for amateurs than the complete removal and inversion of the closet practised by plumbers.

If there is a main trap at the foot of the soil-pipe, the brass screw in the hand-hole must be removed, and the trap dipped or sponged out in the same way ; and the plumbing system of the house may then be considered safe against freezing. After the sealing water of the traps has, however, been removed in the way described, there is no longer anything to prevent air from the sewer from entering the rooms through the unguarded outlets of the fixtures ; so that it is necessary to stop these with wads of paper, and to paste pieces of thick paper over the overflow openings, or the carpets and furniture of the house, when it is occupied again, may be found offensively, and even dangerously, saturated with the foul emanations of the drains.

Many plumbers, who have observed that traps, Salt. after thorough clearing out, often collect water in cold weather, probably from the condensation in them of the warm and moist vapors of the sewers, put a handful of coarse salt in the main trap, after clearing it out, and before replacing the trap-screw ; and the same treatment is some-

times applied to water-closet traps, and to the jet-tubes of siphon-jet closets. The action of the salt is, if water should collect by condensation in the trap, to dissolve in it, forming a strong brine, which, if it freezes at all, only congeals into a soft mass, which is harmless. For iron main traps, and for closets of vitreous china, this treatment is often useful; but salt should not be put into a brass or plated trap, nor should it be allowed to come in contact with brass trap-screws or other fittings, on account of the danger of corrosion; nor should it be put into a closet basin of ordinary earthenware, the glaze of which may be affected by it.

Where plumbing work is left in warm weather, the process of protection is much simpler. It is not necessary to drain the supply-pipes, but it is advisable to shut off the water at the cellar wall, or even at the street, as a precaution against waste of water through the dripping of a faucet, or possible leaks through the spontaneous splitting of a brass pipe, or the breaking of a soldered joint, or from lightning, or from the gnawing of a lead pipe by thirsty rats. In an empty house any of these occurrences may cause great damage. In regard to the traps there is, of course, no danger to be anticipated from freezing, but the circulation of air which goes on in most modern drain-pipe systems causes the evaporation of the water in the traps; so that, after a period varying from two to four weeks, these lose their seal, and sewer-

air passes freely through them, and escapes into the rooms. It is, therefore, desirable that a house left vacant during the summer should be visited about twice a month, and water poured into the various fixtures, so as to keep the traps replenished; but, where this is impracticable, oil should, before the house is closed, be poured into each fixture. Olive oil, or lard oil, or any lubricating oil may be used, or even crude petroleum, but not kerosene, which is too volatile for the purpose. A very small quantity in each trap is sufficient, the object of using it being to cover the water in the trap with a floating film of oil, which will keep it from evaporation for a long time. Glycerine is often used for the same purpose, and answers very well, although more of it is needed, as it dissolves to some extent in the water.

CHAPTER X

GAS-PIPES AND GAS-FIXTURES

It is fortunate for Americans that the introduction of lighting by coal gas into this country found the manufacture of wrought-iron pipes so well developed that they were immediately adopted for distributing the gas in houses, instead of the wretched pipes of thin lead which were for so many years employed for the purpose in England, and even now have not gone out of use. With us, gas-pipes are always of iron, put together with screw joints, and are tested, when the piping of a house is completed, by pumping air into them until the pressure in them is sufficient to raise the mercury in a manometer tube. Unless the pipes are so free from leakage that the mercury in the manometer remains at the same height for some hours, the gas company will not furnish gas to the house ; so that the fact that the house is supplied with gas is evidence that the pipes have been tested by the company's inspector, and found tight ; and, if once proved tight, iron pipes are not very liable to subsequent leakage, unless they have been tampered with or altered after testing. Where such leaks occur, they are most likely to be near the fixtures. In-

ferior gas-fitters, instead of making the outlets, or "nipples," of their pipes just long enough for the fittings to be screwed on, use waste pieces of random lengths; and it frequently happens, in consequence, that the contractor for the fixtures is obliged, before he can put on his brackets or centre lights, to unscrew the nipple provided for him, and put on one of proper length. As the pipes have already been tested, and he has not, therefore, the fear of the inspector before him, the fixture man is not always careful to make the new nipple as tight as the old one, and a concealed leak in the wall, where it is not easily discovered or remedied, may be the consequence. The inferior gas-fitters also frequently find it too much trouble to arrange their pipes so that the nipple projects exactly at right angles with the wall or ceiling, and, as a result, the fixtures, when attached to them, make various angles with the plastered surface. As this is ungraceful, the fixture man endeavors to bring the nipples to the proper position by screwing a long piece of pipe on them, to serve as a lever, and violently bending them to the angle required. The fittings for small gas-pipes are usually made of malleable iron, so that they can accommodate themselves to a certain amount of bending; but if they, or the pipes to which they are attached, should happen to be intractable, a bad leak may be caused in a partition or floor, where it can be reached only with difficulty.

Occasionally, gas-pipes may leak in other places. The inferior gas-fitters sometimes smuggle in split pipes into their work, filling up the seam with red lead putty, which stays in place long enough to enable the piping to pass the inspector's test, but falls out later, opening a dangerous leak; or a fitting may be broken by an accidental blow; or an old and leaky meter may have been furnished by the gas company, or it may not have been properly connected; and, in all these cases, leakages may be caused after the piping has been passed by the inspector; while a leak in a street main may fill the cellars of the neighboring houses with gas.

From whatever source it may proceed, a leakage of gas should never be investigated with the aid of a lamp, or candle, or lighted match. Innumerable explosions, many of them very destructive, have been caused in this way. The proper course, when any serious leak is suspected, is to feel the way, if daylight is not available, to the meter, and shut off the gas from the house. Such gas as has already escaped will very soon dissipate itself, and the pipes can then be examined with safety. If the defect is not found, a fixture, or a nipple, may be unscrewed, and some ether poured into the pipe, closing the opening immediately. The ether vapor will diffuse itself through the pipes, issuing at the leak, which can thus be traced by the smell, and corrected as circumstances may require.

Leaks in or about fixtures are much more common than those in pipes, and are, fortunately, more easily detected. Besides the leaks due to the substitution of a new nipple for one which has been tested, but is of improper length for attaching the fixture, other leaks are often due to a defective joint between the nipple and the fixture. Where the nipple for a ceiling light has been carelessly put in, so that the chandelier will not hang perpendicularly, it is often necessary to attach it to the nipple by a ball-and-socket joint, and such joints always leak. If the connection of the fixture with the nipple is perfect, there may be a leak at the key; and, if the keys are tight, the burners may not be well put on. In the latter case the gas will leak only when the burner is lighted, as the key is the limit of the portion of the fixture which contains gas at other times.

Leaks in
fixtures.

Probably nine-tenths of the leakages of gas which, almost undetected, poison the air of a house, are at the keys of the fixtures; and, in order to guard against or

cure such leakages, the construction of a gas-key should be understood (Fig. 30). In substance, it

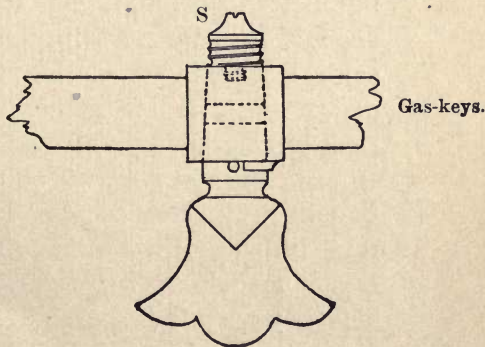

FIG. 30.

consists of a tapering plug, carefully fitted to a conical hole through the body of the fixture. The plug has a hole through it, which can be turned so as to coincide with the bore of the fixture, allowing the gas to pass, or at right angles with it, shutting the gas off; the key itself, which is simply an extension of the plug, serving to turn it as desired. By use, the plug and its seat wear, the plug growing smaller, and the conical hole in which it moves larger, until there would be room enough between them to allow so subtle a fluid as illuminating gas to pass, if it were not for the short spiral spring, S, which is held by a screw to the end of the plug, but presses against the body of the fixture, so as to draw the plug with considerable force into its conical seat. If the plug were cylindrical, it would be drawn far in; but, being tapered, it can only be drawn in far enough to bring it into close contact with its conical seat; and, as the surfaces of the plug and its seat are worn away, the spring draws the plug farther in, still keeping the joint tight. In practice, however, the spiral spring is so short that its action does not last long; and, after a certain amount of wear has taken place, the plug is no longer drawn tightly down to its seat. The key may then be tightened by screwing in farther the screw which holds the spiral spring, so as to bring the latter once more into play; but continued wear again loosens the plug, and a time comes when the tightening screw can be

turned no farther. The tension on the key could, even then, be restored by stretching out the spring, or by deepening the screw hole in the end of the plug; but either of these operations would probably be beyond the resources of an ordinary householder, and it is generally quite sufficient to remember, in opening or closing any gas-key, if worn and loose, to push it slightly upward, so as to leave it firmly sticking in its seat, independent of the tension of the spring. This simple precaution will keep the key from leaking for an indefinite period; and fixtures which would, from wear, leak quite seriously at the key if this were turned, as is common, with a downward pull, will be perfectly safe if the key is always pushed upward in turning.

The joints of swing gas-brackets are made with a tapered plug and spring in the same way; and, as these are not usually subjected to much wear, an occasional tightening of the screw should keep them perfectly tight.

The keys of gas-fixtures are liable to an accident of a very dangerous kind, which should be guarded against. It is obvious that, if the gas is shut off by turning the key so that the hole in the plug is at right angles with the bore of the fixture, it may be let on again by continuing to turn the key in the same direction. It is difficult to judge in a dark room whether the key is left exactly at right angles with the pipe or not, and in order to stop it at the proper point

a peg is inserted in the tapering plug, which strikes against a shoulder on the fixture when the key is turned to the desired angle, and prevents it from going farther. In most cases this peg is nothing but a bit of wire, inserted in a hole drilled for it, and it often falls out, or is knocked out by rough handling of the key, removing the only safeguard against turning the key too far, and thus letting the gas on again, after turning it off. As the light is, of course, extinguished by turning the gas off, that which escapes when it is let on again by turning the key too far passes unburned into the room, rapidly poisoning the atmosphere. Hundreds of people have been killed in this way, particularly in hotel rooms, where the peg of the gas-fixture, in consequence of the rough handling to which hotel furniture generally is subject, has fallen out, so that strangers turning off the gas, expecting to feel the key stopped at the proper point by the peg, and unable in the darkness to see whether it is at the proper angle, have turned it on again, to perish later in their sleep through the slow diffusion of the poison in the room. Some fixtures are made with a solid projection, which cannot be knocked off, instead of a peg; but this adds a few cents to the cost of the key, and it is not likely to be found on fixtures unless specially required. In ordinary fixtures, if the peg is found to have fallen out, so that the key can be turned beyond its proper angle, a bit of

wire of the proper size can be driven into the hole, or a small screw firmly inserted. Either of these will make the fixture safe.

Joints in fixtures, other than at keys, often leak slightly. Such leaks can generally be stopped, at least temporarily, by an application of soap. Any hard soap will answer, and it is usually sufficient to put a little around the place where the smell of gas indicates a leak, and work it into the joint with the fingers. In course of time the soap dries and crumbles away, but a fresh application is easily made. Even keys, if they cannot be kept from leaking except by making them inconveniently tight by means of the screw, may often be advantageously treated with soap in the same way.

Leaky
joints.

Gas-fixtures should be well cared for, as the charge for taking them down, after they have become dingy, refinishing them, and putting them up again, is apt to be extortionate, sometimes exceeding the original price of the fixtures. Except the very costly specimens plated with pure gold, nearly all gas-fixtures are made of brass, covered with shellac varnish, to keep it from oxidation. The brass is finished in a variety of ways before lacquering, some fixtures being highly polished, giving what the dealers call a "gold" finish; while others are rubbed with emery cloth to impart to them an "antique" character; the appearance of antiquity being often heightened by touching the crevices and

Care of gas
fixtures.

hollows with black varnish, to simulate the accumulated dirt of centuries. Some fixtures are brought to a beautiful blue or purple "steel finish," by means of antimony solution, before lacquering; and others are colored in imitation of bronze, while occasional specimens are painted, in black, blue, red, or other colors to suit particular requirements. Many of the so-called "wrought-iron" gas-fixtures are really of painted brass; but fixtures can be had of true wrought iron, as well as of glass, the latter, however, being simply of pieces of glass, in balls, prisms, Venetian flowers or other forms, strung on brass piping, which is plated with nickel or silver when balls or prisms of clear glass are to be strung upon it. The glass fixtures are beautiful and durable, and also very expensive. The iron ones are very durable, and for some purposes beautiful; but the black color generally put on them does not harmonize with delicate decorations, and they do not often look well painted in other colors; so that the great majority of fixtures are of brass.

So long as the lacquer remains on the fixtures, to protect them from the air, they do not corrode, but the color gradually changes, and they may acquire an unpleasant appearance from fly-specks; so that the common practice of covering them in summer with netting has something to recommend it. The bronze and steel finished fixtures, being darker, show stains much less;

but, when they finally become shabby, they are not so easily restored, as the colored finish must be taken off and renewed.

Where the fixtures are of plain brass, the ingenious householder may save himself a good deal of money, and obtain a tolerably satisfactory result, by rubbing them, after they have become unbearably dingy, with fine emery-cloth, followed, perhaps, by crocus-cloth, to give greater smoothness. This treatment will give only the "antique finish"; but, as the antique finish is fashionable, the experimenter need give himself no anxiety on that account; and he will often find that his fixtures please him better in that condition than when glittering from the buffing-wheel.

After the brass has been cleaned in this way to the satisfaction of the operator, it is desirable to protect the work from the air by a fresh coat of lacquer. Brass finishers usually employ for this purpose a thin shellac varnish; but the brass must be heated before the shellac is applied, to prevent it from "chilling," and forming dull spots; so that, for the amateur, the best lacquer is the celluloid varnish known as "Zapon," which can be used on metal at the ordinary temperature, and may be applied with a brush. If lacquer of any sort is unattainable, the brass may be left without it, but the cleaning will soon have to be repeated; while a coat of good lacquer will preserve the brightness of the metal for years.

Lacquering

CHAPTER XI

ELECTRICAL FIXTURES

Incandescent lights.

THE inspection of wiring for incandescent lights in buildings, on behalf of the insurance companies, is now so rigid that the householder whose wires have been accepted by the insurance inspector can feel himself tolerably safe in regard to them. They should, however, be occasionally examined, where visible, to make sure that the insulation is not wearing off, and that they are not exposed to water. Any wet surface, or damp rag, or piece of metal in contact with the wires, which can act as a medium, even of very slight electrical communication, between two wires of opposite polarity, will increase the amount of current used, as shown by the meter, without producing any useful result; and, if the leakage is serious, it involves great danger of setting the house on fire. Safety-fuses, also, in dwelling-house work, are frequently fixed on wooden boards, and enclosed in a wooden cabinet, although the burning out of a fuse, through an accidental short-circuit or otherwise, often sets fire to dry woodwork near it.

Incandescent lamps themselves are often carelessly handled, particularly where they are at

tached to flexible wires, as is frequently the case in dwelling-houses. It should never be forgotten that the common belief, that an incandescent lamp never gets very hot, is correct only when there is a free circulation of air around it; and, when this circulation is impeded, the bulb soon becomes hot enough to set fire to inflammable materials. Destructive conflagrations have been caused by leaving incandescent lamps, attached to a flexible wire, in contact with bundles of cloth, or similar articles, and it is hardly possible to exercise too much care in keeping such lamps out of harm's way.

Where current for incandescent electric lights is not available, an electric spark is often used for lighting gas, either in a "pendant" or "pull" burner, or an "automatic" burner. In the "pendant" burner the pulling of a chain serves to turn on the gas, and at the same time to send a spark through it between two platinum wires, which are made to pass by each other, with momentary contact in the escaping stream, a second pull turning the gas off again. In the automatic burner the gas is turned on or off by means of electromagnets, concealed in the casing of the burner, the current which operates them being controlled by one or more pairs of buttons, placed in any convenient part of the house, and serving at the same time to produce the necessary spark for lighting the stream of gas. If well put in, and well cared for, a system of this kind is extremely

Electric
gas-lighting

convenient, and gives very little trouble. The pendant, or pull, burners are kept free from any leakage of gas, the supply being controlled by a tapered plug, just as in the case of an ordinary key. In the automatic burners, as the tapered plug must be put in so loosely as to be readily thrown in either direction by the attraction of the little electromagnets, there is much more danger of leakage; but, if obtained from a good manufacturer, they are generally reliable. The electrical part of the system, however, is easily thrown out of order by carelessness, and its operation should be understood, so that any derangement may be quickly and intelligently remedied.

The current for electric gas-lighting is obtained from a battery, usually of six or less cells, of the ordinary open-circuit type, with carbon prisms for conducting electrodes, the soluble electrode in each cell being a rod or plate of zinc, and the cells being filled with a saturated solution of ammonium chloride. As the battery current is too low in tension to give a spark capable of lighting a stream of gas, a "spark-coil," consisting of a large wooden spool, wound with insulated wire, and having a "core" of iron wires, is introduced in the circuit, by which the tension of the current is sufficiently raised to give the spark desired.

Battery.

In order to do their work well, the cells of the battery should be filled about two-thirds full of the ammonium chloride solution; the carbon

prisms, which are generally secured by rubber bands to a "pole piece" passing through the glass cover of the cell, should be in place; the zinc rod forming the soluble electrode should be in good condition, and the wires, which should connect the zinc of one cell to the carbon pole piece of the next, must be firmly secured by their appropriate binding-screws; the extra wires, one from the carbon at one end of the battery, and the other from the zinc at the other end, being properly connected with the spark coil, and through it with the wires of the lighting system. To produce the spark required it should then only be necessary to make momentary contact, by means of the appropriate button, for the automatic burner, or to draw the platinum wires of a pull burner against and past each other by means of the chain; and, if the spark fails to appear, a systematic investigation should be made to determine the cause of the trouble.

The burners should first be examined, removing for the purpose the cap of automatic burners, as it often happens that the difficulty is not electrical but mechanical, resulting simply from the gumming up of the moving parts of the burner with oil and dust, or the displacement of the ratchet wheel which actuates the gas-key in the pull burners, or of a spring, or of the platinum wires, so that they do not come in contact when drawn past each other by the chain, or by the electromagnets of an automatic burner.

If, after any defects in these particulars have been remedied, by washing off old oil with kerosene if necessary, or by replacing any disarranged parts, the spark still fails to appear, the electrical portion of the apparatus may be examined. If the battery has been long in use, the sal-ammoniac solution may have evaporated to dryness, or may have been reduced to so low a level as no longer to act vigorously on the zinc; or its chemical energy may be exhausted, as will be the case after a year or two of use. In any case the liquid in the cells should be filled up to the two-thirds level, by adding to what is left in them either water alone, or a fresh saturated solution, made by dissolving sal-ammoniac in hot water. The cells should not be filled more than two-thirds full, or the solution will creep over the edge by crystallization. Pure ammonium chloride only should be used, such as is sold by dealers in photographic goods and general chemicals, put up in pasteboard boxes, or by dealers in electrical goods in small paper bags, each containing a sufficient charge for an ordinary battery cell.

After the refilling of the cells, a few minutes should be allowed for the battery to recover its powers, and another attempt may be made to obtain a spark. If this is still unsuccessful, the zincs may be lifted out of the cells and examined. They dissolve slowly, and the immersed portion of one or more may be found to have disappeared, of course suspending the action of the battery.

Replacing the zincs which are nearly or quite past their usefulness by new ones, a supply of which may with advantage be procured at any electrical goods store and kept on hand, the wires should next be inspected. It is very possible that they may be found wrongly connected, or hooked loosely over the binding-screws, instead of being firmly held under them so as to make good electrical contact; or a wire may have been corroded through and separated by contact with sal-ammoniac solution, and the continuity of the current thereby broken; or the wires connecting the battery with the spark-coil, or the spark-coil with the house system, may be broken, or corroded, or loosely connected, or short-circuited, either with each other or with some extraneous conductor, often the gas-fixture itself.

If the battery has enough energy left in it to give a small spark, although not a sufficiently vigorous one for lighting gas, it may be used to test the house wires for short-circuits by disconnecting the main wire from the carbon end of the battery, and attaching to the carbon a short piece of wire for use in testing. All the house wires that are accessible may then be touched with the end of this testing wire, and the appearance of a spark will show a short-circuit in the wire touched. The reason of this is that all the wires in the house system are interrupted at some point, the pressure of a button, or pulling of a chain, being necessary to close the connection;

Testing for
short-
circuits.

and if a current from the battery can pass through any one of them without the pressing of a button or pulling of a chain, the circuit of which that wire forms a part must be improperly closed at some point of its course, so that the current passes without the interposition of the button or chain. The effect would of course be the same without disconnecting the house wires, but it would be invisible, and the object of making the disconnection and using the testing wire is simply to reveal the passage of the current by a spark.

If, as is the practice of the best contractors, every house wire is furnished with a tag, near the battery, showing to what circuit it belongs, the detection of the one requiring attention will be easy; and, even if there are no such tags, the test will furnish useful indications as to what further steps may be necessary.

If no short-circuit is revealed by the test, the house wires may be connected again, and the buttons which control the automatic burners examined, by unscrewing and taking off the plate. The contact springs, which are pressed by the button to make connection, sometimes break, or fall out of place, either short-circuiting the wire, or making the button useless; and the wires sometimes slip out from under the binding-screws.

Polarization
of battery.

If everything is found in order here, the trouble is probably due to the polarization of the battery, which, as a matter of fact, is a very

common accident with electric gas-lighting batteries.

These batteries, like those used for operating electrical bells and burglar alarms, are always of the "open-circuit" type, in which the chemical action which generates the electricity is suspended except when the electrical current is actually passing; so that, until the circuit in any wire connected with it is completed by making contact between the separated portions, either by pressing a contact spring with a button, or by making the platinum wires of a pendant burner meet by pulling the chain, the battery remains quiescent, no chemical change taking place in it. This property of open-circuit batteries particularly adapts them to house work, where they are called upon only occasionally for currents; but it is accompanied with the inconvenience that, being suited only to momentary currents, they deteriorate rapidly if the duration of the current is prolonged, the carbons of the cells becoming saturated with bubbles of hydrogen, which prevent further chemical action. This effect is called polarization, and any short-circuiting or crossing of the wires, by permitting the passage of a continuous current, soon polarizes the battery and makes it inert. If the current passes only for a few hours, the hydrogen bubbles which fill the pores of the carbons may be slowly absorbed, so that, after it has been allowed to recuperate for several days, the

battery may regain its powers; but a current continued for several days polarizes the carbons so effectually that they can be restored only with difficulty.

In pendant burners, where the current passes, in the form of a spark, when a light platinum wire, arranged with a spring, is drawn past a short fixed wire, attached to the burner in such a position that the spark will be in the stream of gas, the spring wire should be drawn, by means of the chain, entirely past the fixed wire, so that, after making contact, it will pass beyond, opening the circuit again; and, when the chain is released, the wire, which is drawn back by a spring, should brush past the fixed wire, making a second contact, accompanied by a second spark, and continue its course, again opening the circuit. As there is a certain amount of friction between the two wires, as one brushes past the other, the force of the spring is sometimes barely sufficient to overcome this friction; and, if the chain is released slowly, the wires may be left in contact. This, of course, permits a continuous current to flow, so long as they remain in contact, and the battery, in consequence, immediately begins to lose its efficiency by polarization; so that, a few hours later, it will give only a feeble spark, or none at all, at any of the burners.

As soon as this phenomenon is observed, all the pull burners should be immediately exam-

ined, to see if the platinum wires have been left in contact; and if any are found in that condition, they should at once be separated. The apparatus must then be left to itself for three or four days, or even for a week, and at the end of that time the power of the battery may be found fully restored. If, however, this should be insufficient to depolarize it, new carbons may be put in; or the old ones may be lifted out of the cell and soaked for an hour or two in hot water, or moderately heated in an oven, to drive the hydrogen bubbles out of the pores, and then replaced.

The battery used for operating electric bells is similar to that for electric gas-lighting, but smaller, two or three cells being sufficient; and no spark coil is interposed in the circuit. It is liable to polarization in the same way, if the wires are crossed without insulation, or are otherwise short-circuited; and the contact springs, under the buttons, not infrequently break, making the button inoperative. These troubles, however, are easily remedied, and the battery cells, if not polarized, may at any time be restored to efficiency by new zincs, and fresh charges of ammonium chloride; so that very little skill is required to keep a bell battery permanently in good condition.

Electric
bells.

Burglar-alarms are operated in the same way as other electric bells, and by a battery of the same sort. As, however, the bells are rung by

Burglar-
alarms.

means of contact springs brought into action by raising a window, or opening a door, or stepping on a door-mat, and as contact springs in the frame of a window or door are very liable to deterioration by weather or by accident, the system should be tested at regular intervals, and any defects corrected, if it is to be kept in efficient condition. The wires of burglar-alarms also, particularly if they are put in by irresponsible travelling electricians, are often very carelessly run, over floors, or on walls, so that they soon become damaged.

The householder of a scientific turn of mind will find interest, as well as economy, in caring for the electrical appliances connected with his dwelling; and, with a little insulated wire, a battery cell or two, and a few switches or buttons, he can often arrange very convenient temporary call-bells or burglar-alarms for himself.

CHAPTER XII

THE CARE OF WOODWORK

THE woodwork used for finishing a house, as distinguished from that which forms a structural part of it, may be divided into two portions, one comprising the "standing finish," including the bases, frames, and architraves of doors and windows, wainscoting, panelling, mantels, and other ornamental woodwork fixed in position; while the other will include the floors and stairs, which are usually of different material from the doors and standing finish, and require very different treatment. As, however, the treatment of floors and stairs is much simpler than that of woodwork of other kinds, it will be best to consider it first.

Floors to be covered with carpets are best made of white pine, where it can be procured. Clear pine is extravagantly costly, as the supply is very limited, but in certain districts, where the forests have been replanted, second quality pine can be obtained at a moderate price, which, although it contains many knots, and is unattractive in appearance, is soft, so that tacks are easily driven into it, shrinks little, and lies permanently flat, so that carpets laid over it wear

Floors.

Pine floors.

Spruce
floors.

well. It is, however, unsuited for staining or varnishing, as it is so soft that the stain soon wears through, and the knots show even through a dark stain. On account of the greater expense, as well as the rougher appearance, of second quality pine, most builders make floors intended to be carpeted out of spruce, which is cheap, nearly free from knots, and white and agreeable in appearance when fresh. Its disadvantages are that floor-boards made of it are disposed to curl up at the edges, forming ridges, which greatly hasten the wearing-out of a carpet laid over them; while there is little adhesion between the annual rings of the tree, so that the wood, when dry, particularly if cut from old trees, is liable to splinter. Although spruce is not quite so soft as pine, tacks are easily driven into it, and it makes a tolerably attractive floor when stained; although the stain soon wears through. The best spruce flooring for staining is that cut from sapling trees, the wood of which is much softer, and less disposed to splinter, than that from old trees.

Staining
floors.

It is very common to stain floors of soft wood, such as pine or spruce, either all over, or around the edges, leaving the middle to be covered with a rug; and amateurs often find much satisfaction in experimenting in this way. Although oil stains are sold for the purpose in cans, ready mixed, and labelled "light oak," "dark oak," "cherry," and other colors, and can be put on

with little trouble, they are apt to give a muddy effect, unless made very dark; and the best results are obtained, although with more trouble, by using water stains, which can also be bought of various colors, ready for use. These soak much better than the oil stains into the grain of the wood, and give a clearer color. They must, however, be varnished after they are thoroughly dry, using two, or even more, coats of some first-class floor varnish, such as Murphy's, Crockett's, Rosenberg's, the Detroit Varnish Company's, or many others. Such varnish as this cannot be bought for less than \$3.50 or \$4.00 a gallon; but it is a waste of time to put on a cheap varnish, which will either be so sticky that dust will cling to it, and soon blacken and ruin the floor, or will contain rosin, so that every spot of water, and every nail in a boot-heel, will make a white mark on it. As it is the varnish which defends the floor against wear, it is hardly possible to put on too much of it, and it is impossible to have it too good. If the skill of the artist is not sufficient to put it on evenly, it may be rubbed with fine sandpaper, to smooth it, before the last coat; and a good effect, less glittering, as well as less slippery, than the plain varnish, may be obtained, after the last coat of varnish is dry, by going over it with a little floor wax, and polishing with a rag or brush. An oil stain is also greatly improved, both in appearance and durability, by varnishing, and in appearance, although not

much in durability, by waxing; but it never acquires the transparency and clearness of a well-varnished water stain.

In order to preserve the appearance of a stained floor, it should be watched for signs of wear, and the worn spots retouched with varnish before the protecting covering is worn through. If the wear penetrates the varnish, and reaches the stain, it is difficult to patch it so as not to make a spot.

Even if the floor, before staining, is already worn or splintered, it can be made presentable by planing out the splinters or worn places, so as to expose a new and fresh surface. It is not necessary to go to the expense of planing the whole floor. Although planing only in spots will leave the surface uneven, this is not a serious fault in a floor, in comparison with a good color and pleasant gloss. The oak floors of an old French palace are usually anything but even, yet they lose little of their effect in consequence.

Where a soft-wood floor is too much worn and splintered in the middle to be worth staining, but is in tolerable condition around the edges, as is often the case, a good effect can be obtained by staining only the border, leaving the middle of the floor to be permanently covered by a large rug, or "art square" carpet, or, still better, by a special composition, consisting of a centre of a plain-colored velvet or tapestry carpeting, selected to suit the scheme of color intended for the room, with a border of either tapestry or Brussels, the

latter being in some respects preferable, as the contrast between the cut pile of the tapestry or velvet centre and the uncut pile of the Brussels border makes the centre look softer, and there is a greater range of Brussels borders to choose from. The border may, of course, be of any width, but, as a general rule, the full Brussels width of twenty-seven inches would be suitable only for a rather large room, and an eighteen-inch border would be better in most cases. If plain tapestry or velvet carpeting cannot be found of a suitable color, felt will answer, but it is less easily kept clean than a material with a cut pile. In any case, the housekeeper is likely to hear animadversions from the neighbors on the folly of using plain carpeting, which "shows every mark"; but people who have to consider economy may console themselves by the reflection that a plain carpet, if of reasonably good quality, wears much longer than a figured one, partly because certain dyes corrode the wool in figured carpets, and cause the figures of that color to wear through first, and partly because some dyes fade more than others, and the fading of the figures of the most fugitive colors makes the whole carpet look shabby; and those who look to artistic pleasure, as well as economy, will find themselves repaid a hundred-fold for a little extra trouble in brushing by the restfulness of the broad mass of color in the middle of the room, softened, as it always is, by the varying shadows upon it, and even by

fading, which lends tone to a plain carpet where it only brings shabbiness to a figured one. In case an effect of special interest is desired, a beautiful rug may be made by embroidering on plain carpeting, using in preference naturalistic motives, such as a spray of wild roses, or of trailing arbutus, or various other flowers. The embroidery should be large and simple, to be effective, and can be done in worsted or silk, or a mixture of the two.

Floor-
borders.

To return to the stained floor-border which is to frame these creations, it will generally be found that a width of twenty inches for the exposed part of the staining is the most satisfactory, whether the room is large or small. With a narrower border than this, chairs standing against the wall are liable to have their front feet on the rug, tilting them back unpleasantly, while, with a wider border, the rug which covers the middle portion of the floor is apt, even in a large room, to have a shrunken appearance, which is disagreeable. Bay-windows and similar recesses may, however, with advantage have their whole floor stained, the border being carried straight across them; and the borders at the ends of the rooms may without objection be wider than those at the sides. In any case, the border should be painted three or four inches wider than it is intended to show, so that a slight displacement of the rug may not disclose the bare wood.

Where a stain cannot be found or made which harmonizes with the rugs or furniture, or where the floor has already been stained, and allowed to become irretrievably shabby, it is often best to use paint, which can, of course, be made in any color. The paint should be mixed thick, with plenty of japan drier, or boiled oil, so that it may harden quickly, and may be put on in two, three, or more coats, according to circumstances; and it is desirable to varnish it afterward, for protection against scratches. With dark madder brown, or "antique blue" paint, or other deep, rich colors, harmonizing with the rest of the room, beautiful effects can be obtained. Our ancestors were in the habit of painting the floors of their rooms white, and decorating them with bluish veins, suggesting, although not usually with deceptive accuracy, a marble pavement; or, for variety, they imitated granite slabs with slate-colored paint, sprinkled with little drops of white; and it may be reserved for some clever householder of the present day to invent painted and varnished floor-borders, decorated with pink and white pond-lilies, for example, floating with their green leaves on a dark blue ground, with brown reflections here and there, suggesting the mud beneath; or, perhaps, clusters of daisies, on a ground of green, in the William Morris manner, which would be charming.

Painted
floors.

Much more satisfactory, where it can be afforded, than a floor of spruce or pine, however

Hard-wood
floor.

well stained or painted, is one of hard wood. The cheapest flooring wood which has any pretensions to be called hard is North Carolina pine, which, unless specially selected, costs little more than spruce. The boards, if of ordinary stock, show a large proportion of sap-wood, which injures their appearance, and they are hard enough to turn the points of tacks, so that they do not receive carpeting well; but, as a compensation for this, they can be kept at a tolerable polish with wax; and, in a new house, it is possible to select the boards, so that those in the best rooms will show no streaks of white sap. Georgia pine ranks next above North Carolina pine, both in hardness and cost. It takes a good polish with wax; but, for flooring, it is necessary to use "rift" boards, the surface of which is cut nearly normal to the annual rings of the log; and these rings, being cut across, show a grain of fine parallel lines, which is rather monotonous. A much handsomer grain is found in the "slashed" boards, which are cut nearly tangent to the annual rings, and show broad mottlings; but these mottlings are composed mainly of brittle rosin, which soon crushes under wear, setting free great slivers of wood, and ruining the appearance of the floor. Similar mottlings are seen in boards of North Carolina pine, but the annual rings are much more adherent in this timber than in Georgia pine, so that it is little disposed to splinter.

Georgia
pine.

Above Georgia pine, both in expense and hardness, come maple, ash, birch, and oak; and, beyond these, cherry, mahogany, black walnut, and other so-called "fancy" woods. Of the ordinary hard deciduous timbers, maple is the cheapest, and makes a very tough, durable floor, admirable for hard wear; but the boards, in seasoning, acquire a bluish tinge at the ends, which injures the appearance of a floor laid with them; so that maple is not often used for entire floors in private houses, except for small rooms, where selected pieces, especially if they can be chosen with a "bird's-eye" or curly grain, give a very pretty effect. With maple, as with all other deciduous woods, the boards must be narrow to give a good effect, as they shrink much more than coniferous timber. Two and one-half inches is a common width for maple flooring, and two inches is still better. For parquetry, or inlaid floors, maple is much used, on account of its whiteness, which serves to mark the pattern of the inlay. Maple.

Ash is little more costly than ordinary maple, but it is unsuited to the severe wear of a floor in a room which is much used, as the annual rings do not adhere together strongly, and the floor soon begins to "sliver up" in the places where the most wear comes. Except for this, ash would be a hard and handsome flooring material, and it may still be used successfully, in place of the more expensive oak, for stairs and floors not Ash.

Birch.

exposed to much traffic. Birch is a very hard material, containing a large proportion of white sap-wood, enclosing heart-wood of a beautiful pinkish brown. It has only a limited market, but hardly any floor can be handsomer than one of birch heart-wood, in two-inch strips, well polished.

Oak.

The best of all ordinary flooring woods is, however, oak, which is hard, of a varied and agreeable grain, and so tough that it is not disposed to splinter, even when "slashed," or cut tangent to the annual rings. It is, however, liable to knots, and streaks of white sap, so that a considerable percentage of the stock must be wasted in laying a good floor.

Whatever wood is used should be in boards seven-eighths of an inch thick. At certain times it has been common to lay "wood carpets," consisting of slips of various woods, one-quarter of an inch thick, glued on cotton cloth, over spruce floors: but unless the strips are nailed through from the face, which covers the floor with nail-holes, they soon became loose. Parquetry floors are made, in many cases, with pieces three-eighths of an inch thick, glued and fastened to a backing of half-inch pine; and, when well made, they are durable.

For giving to a floor of any hard wood the polish which forms one of its chief attractions, wax only should be used. Nearly all painters have a mania for varnishing hard-wood floors,

some from habit, and some from the facility with which a polish can be obtained; and will argue by the hour in favor of the practice; but the householder who looks beyond immediate effect, and desires to see his floors clean and shining when his neighbor's varnished floors are hopelessly black in the corners; and diversified in the middle with worn spots of white, which no patching or staining can conceal, should firmly refuse to allow varnish of any kind to touch a hard-wood floor; and he may take satisfaction in knowing that the very best painters will support him in this refusal. The oak floors in the French palaces have never had anything but wax on them, and although the feet of visitors have, in two hundred years, worn the boards nearly through, they are as bright as when they were first laid; while a varnished floor is rarely presentable after ten years' service, and can be brought back to tolerable condition only by costly scraping and refinishing.

French floors are polished with simple beeswax; but the mixture of beeswax, paraffine, and turpentine sold in cans under the name of "Globe Wax," "Butcher's Polish," and various other appellations is more easily applied, and is less sticky than pure beeswax, so that it needs less frequent rubbing to keep it bright. Before the wax is applied on a new floor, the floor should receive two coats of a mixture of equal parts of linseed oil and turpentine, with enough japan to make it harden over night.

Waxing
floors.

Both the oil and turpentine should be pure, as the fish-oil and benzine often sold for them will leave the floor sticky. The purpose of applying the oil is to bring out the grain of the wood, and prevent subsequent grease spots from showing on the floor, as they would if the wax were applied without previous oiling. The mixture of turpentine causes the oil to soak much more deeply into the wood, and, by two coats, the grain, with the aid of the japan drier, is to a certain extent filled and hardened, so as to take a better polish with the wax. After the wax has been applied, no oil should ever be used on a floor. The wax will prevent it from being absorbed, and it will simply form a sticky film over the surface, which will soon collect dust and turn black.

After the oil and turpentine treatment, and before waxing, it is common to fill the pores of oak and ash floors with a paste "filler," well rubbed in. As this fills up the pores to the line of the surrounding tissues, a more uniform polish can be obtained subsequently; but, unless a very high finish is desired, the filler may be dispensed with, and the floor will be less slippery if it is left out. Most painters, after filling an oak floor, insist that it is necessary to go over it with "a thin coat of shellac," to "prevent the filler from coming out"; but the application of shellac, like that of any other varnish, will cause the floor to wear into spots, and it is much better to let the filler come out, if it chooses, than to keep it in by

such means. As a matter of fact, the filler rarely shows any disposition to leave its place in the floor after a coating of wax has been put over it.

After the floor has been filled, if a filler is used, and when the filler and the preceding coats of oil are perfectly dry and hard, the waxing is begun by covering the whole floor with the wax and turpentine paste, put on, not too thickly, with a rag, and leaving it over night to harden. The next morning the rag is again applied with some fresh paste, the turpentine in which dissolves the surplus wax left on the floor the day before, and renders the coating uniform. After drying for an hour or so, the whole is polished with a weighted brush, rubbing with the grain of the wood, and finished with a woollen rag, applied either by hand, or by tying the rag under the weighted brush. If the japan is omitted from the oil and turpentine, or inferior filler is used, so that the wood is greasy, it is useless to apply the wax, as the latter will unite with the oil, and cannot be polished; while it will prevent further drying of the oil, by excluding the air, so that the wax finishing must be left until the previous applications are well hardened.

After once waxing, the floor will need no further attention for a year, except an occasional rubbing with the weighted brush to keep up the polish. At the end of that time a thin coat of wax may be applied, particularly over the places

where the most wear comes, in the same way in which the first application was made, by leaving it over night to harden, and rubbing it down the next morning with a rag dipped in a little fresh paste, and annually thereafter the operation may be repeated; but, in the intervals, no fresh wax should be put on, the weighted brush or a warm woollen rag, if the wax has been whitened by water, being depended upon to keep up the polish. The footmen in French houses polish the oak floors every morning by skating over them with a brush tied to one foot; but, with the paraffine mixture commonly used in this country, so much labor is unnecessary, a weekly, or even monthly, brushing being sufficient.

Oak stairs, and ash floors and stairs, should be treated in the same way as oak floors, first oiling with linseed oil, turpentine and japan, then filling, if a high polish is desired, and finishing with wax. So treated, they will retain their beauty indefinitely. Floors of maple, birch, Georgia and North Carolina pine, and the fancy woods are similarly finished, but most of them are so close grained that no filler can be used on them, as there are no pores to fill, and for the same reason they take much less wax than an oak or ash floor, but require, as a rule, more rubbing to produce a good effect.

**Kitchen
floors.**

Kitchen floors, which are usually of Georgia pine, are less suited for waxing, for the reason that much water falls on them, and makes the

wax white and dull. The best treatment of all would be to saturate the floor with paraffine, by melting it in with hot irons, as is often done in hospitals. Such a floor would never absorb water or dirt of any kind, but it would be expensive; and most people, forgetting the hours that their servants spend in washing floors which, with proper treatment, would never need anything more than wiping with a damp cloth, choose the cheapest finish that they can find. Usually, a coat or two of linseed oil is put on; and, as the mucilaginous gum contained in linseed oil remains soft in a warm, moist atmosphere, the dust and dirt of the kitchen stick to it, forming a black coating which it is almost impossible to wash off. A thick paraffine oil is sometimes used instead of linseed oil, but with little better results. Some housekeepers wash their kitchen floors with milk, which is said, by repeated washings, to give a shining surface, which is not sticky; but there are sanitary objections, to say nothing of entomological ones, to filling the seams between the boards with dried and decaying milk. Probably wax in some form, notwithstanding the fact that the provision-man's wet boots make tracks over it, is the best application. In order to fill the pores and crevices of the wood as thoroughly as possible with it, the ordinary waxing may be supplemented by sprinkling the floor with powdered paraffine, scraped off a paraffine candle, or from the blocks sold for the purpose at

the large grocery stores. These paraffine scrapings are much used for scattering over ball-room floors, the feet of the dancers soon forcing them into the pores of the wood; and the ordinary traffic of the kitchen, aided, perhaps, by a hot iron in the corners, would in time give something of the hard, impervious surface, which, if it is desirable in a ball-room, is even more so in a kitchen.

When an oiled kitchen floor has become so black that the most persevering maid gives up the attempt to make it presentable, the usual course is to paint it. As even the best paint shows marks from boot heels and furniture, such a surface is less desirable than one made by thorough treatment with paraffine; but sometimes nothing better can be had. In such cases paint mixed thick, with plenty of japan drier, should be used, so as to get the floor well covered with one coat, and insure its drying within a reasonable time; and it is judicious to employ a single pigment, such as French ochre, raw sienna, burnt sienna, or raw umber, without mixing it with any other color, so that the worn spots which will appear later in front of the sink, and around the doors, can be retouched with the contents of another can of the same color, without recourse to the tedious, and generally unsuccessful, operation of mixing new color to match the old.

After a floor of any kind has once been properly waxed, it often happens that housekeepers, or

over-zealous servants, in their anxiety to keep it in a state of brilliant polish, or to restore it when its original lustre has become dimmed, put on too much wax, which lies on the surface of the floor, and collects dust, giving the wood a gummy, blackish look. The remedy for this is to take off the surplus wax with a little turpentine. Some of the manufacturers of floor waxes, knowing the ways of housekeepers, put up and sell, under the name of "Reviver," or something of the kind, a mixture of a small amount of wax or paraffine with a large proportion of turpentine. This compound, rubbed with a rag over a floor suffering from too much wax, simply dissolves and removes the blackened surplus, revealing the floor underneath in its pristine brightness.

All floors are more or less subject to staining or discoloration from various causes. The worst discoloration is that which comes from the blackening of varnish or oil on the surface, and it can only be remedied by scraping the coating off, to the bare wood. This operation, when carried out with steel scrapers, is tedious and expensive, as the particles of sand and grit embedded, with other dust, in the sticky varnish, quickly destroy the edge of the scraper; but either this or, in the worst cases, planing, is necessary, as the acids, alkalies, or trade nostrums used by painters for removing old varnish leave the wood in an incurably uneven, chalky condition. After the floor has been thoroughly scraped, it should be treated

7
Removing
stains from
floors.

with the oil and turpentine and japan mixture, and waxed.

Grease spots.

Where the preliminary oiling of a waxed floor has been omitted, as is often the case where the proper method is not understood, the floor will show grease spots, particularly in dining rooms, where greasy crumbs will inevitably fall upon it. The grease can be tolerably well removed with turpentine, and the spots, if left to themselves, will gradually be absorbed and disappear; but the best way to cure them, as well as to prevent the formation of others, is to wash off the wax with turpentine, oil with linseed oil, turpentine, and drier, and refinish with wax.

Oak floors are subject to a sort of staining which often gives housekeepers much trouble, at the same time that it affords an interesting study in chemistry. Every one knows that ink is made by mixing gallic or tannic acid with a solution of iron, the two forming a deep black compound. As oak wood contains tannic acid, it is only necessary to wet it with a solution of iron to produce a deposit of ink in the fibres of the wood; and the necessary iron solution is furnished by a wet umbrella, or cane, or by the wet tires of a baby-carriage, or an old tin pail, or a multitude of other objects, any of which, if left standing on the floor, will leave a black mark. Fortunately, this inky mark is very easily removed with oxalic acid, which is the general remedy for all varieties of iron stains.

It is only necessary to dissolve a small quantity of the oxalic acid crystals in a cup, keeping them carefully out of the way of children, as oxalic acid is a dangerous poison, and make a little puddle of the solution over the black spot in the floor, leaving it, if possible, over night. In the morning the stain will have disappeared, and nothing more is required but to wash off the oxalic acid, and, after the spot is thoroughly dry, polish with a little wax. Stains of real ink can be removed in the same way, provided the ink is of the standard kind, made with gallic acid and iron; but purple ink, or any other variety made with aniline colors, will resist oxalic acid. Some aniline colors, but not all, can be removed with saleratus, or washing soda, and the same substance will take out stains of the ordinary laundry bluing, which is made with Prussian blue. Strong alkalies, such as potash or caustic soda, or even strong ammonia, should not be applied to oak, as they will stain it brown; and wet lime, or mortar, will also make a deep and indelible brown stain, which can only be removed by planing. Fortunately, with a floor finished in wax, mortar stains, spots burned by sparks, or other stains which cannot be removed by easier means, can be planed out, and the place waxed and rubbed, without disfiguring the floor. Although the fresh surface of the wood may at first be paler than that around it, exposure to air and light will soon bring it to

the same shade; and it is better to wait for them to do their work than to apply a stain, which does not penetrate far into hard wood, and soon wears off, leaving unpleasant-looking spots.

Washing
hard-wood
floors.

As the coating of wax on a floor is dulled and whitened by the contact of water, while good varnish is not so affected, the advocates of varnished floors often claim superiority for their favorite finish on that account. As a matter of fact, however, most varnish is more injured than wax by water, the surface being rendered temporarily soft and sticky, while the whitened surface of the wax, after the water has dried away, needs nothing but rubbing with a warm woollen cloth, or a weighted brush, to bring it back to its former polish. In general, however, the washing of hard-wood floors of all kinds should be avoided. With Georgia pine floors the water hastens the deterioration and splintering up of the boards, and, with any wood, the accumulation of water and dust in the seams between the boards causes discoloration, and promotes the rotting of the floor. The latter is often a serious matter in kitchens, where decay, once started, advances rapidly in the warm, moist atmosphere; and the oil-cloth, which is frequently laid down to conceal the first stages of the malady, soon completes the ruin of the floor, by excluding the air.

Although it may sometimes be necessary to wash the kitchen floor, the other hard-wood floors

of a house will rarely, if ever, need anything more than an occasional wiping with a cloth, dampened sufficiently, if necessary, to take off mud, or other adherent matters, but not so much that water will escape from it into the seams.

Standing finish of hard wood, although it may, with beautiful effect, be treated with wax in exactly the same manner as a floor, is usually varnished, and such treatment is much less objectionable for this purpose, as the varnish does not tend to wear off in spots, or to accumulate dirt, as it does on a floor. It is, however, very necessary that the varnish should be good, as a cheap varnish will show white spots where it is bruised, and soon becomes shabby, where a good varnish will retain its smooth appearance indefinitely. Shellac varnish, put on in four, five, or six coats, and rubbed down with emery-cloth and oil, or, if a higher polish is desired, with pumice-stone and water, forms the best application of the kind for doors and standing finish; but it is expensive, and two coats of some good, hard interior varnish, rubbed down in the same way, form a tolerable substitute. Whatever varnish is used should be carefully treated, and the coating renewed before it is too late, as worn spots in varnished work cannot be retouched successfully. With good varnish, a damp cloth may be used to remove spots on the surface, but it should not be too wet, and water should not be allowed to get into seams or nail holes. If the varnish is in-

Standing
finish.

ferior, even a damp cloth will, after a little time, cause white or yellow spots to appear on the surface. These are caused by the cracking and disintegration of the varnish; and, while they can be to a certain extent concealed by rubbing them with "Scotch Polish," used and sold for the purpose by furniture dealers, the disintegrated varnish soon crumbles off, leaving the bare wood.

When a householder finds himself obliged to deal with varnished woodwork which has been neglected, and is unwilling to go to the great expense of having it scraped down to the bare wood, and refinished, he will find a can of floor wax an invaluable resource. Unless the spots where the varnish is worn through have become stained, by atmospheric action or otherwise, a careful application of the wax, and subsequent rubbing, will bring them to a close approximation to the appearance of the surrounding varnish; and the approximation will be still closer, and the appearance of the entire varnished surface improved, by treating the whole with the wax, which will not only give a uniform lustre, but protect from wear such varnish as remains. With good floor wax there is no danger, as is often pretended, that the surface will be made sticky. Even the hand-rail of a staircase may be finished in wax, without fear of trouble from this source.

Where the interior woodwork is painted, instead of being finished in the natural color, the

task of the householder in keeping it in presentable condition will be in a certain degree lightened; for, if painted woodwork shows marks more conspicuously than that treated with varnish, its covering is more easily renewed. Our ancestors had a way of painting their woodwork with a white, glossy paint, which was very hard, and could be washed with a wet cloth without injury; but, according to the modern painters, this art is lost, and those persons who desire washable white paint in their houses must incur a great expense in having the woodwork treated with "enamel," in five or six coats. It is true that the modern enamel, if well put on, so that it does not blister, or stick to persons and objects coming in contact with it, as is not unfrequently the case, is more beautiful than the ancient paint, being smoother, and less subject to netlike cracks; but it is not every householder who can afford it, and it would be very desirable to revive the colonial practice. The colonial paint was mixed with boiled oil, which gives a glossy, varnish-like surface, and was, as we know, highly esteemed by our forefathers; but the real boiled linseed oil is said to be unknown to the trade now, its place being taken by a mixture, sold under the same name, but of different properties.

Until the glossy old paint is reinvented, those householders who cannot indulge themselves in the luxury of enamel must be content with the

ordinary paint, either "flatted," or in "oil finish," or "china gloss." The flatted paint, in which the last coat is mixed with turpentine only, has a dead surface, possessing a marvellous capacity for getting marred and discolored. The touch of a finger will leave on such paint a perceptible mark, which cannot be removed, since flatted paint cannot well be washed, and is only to be cured by repainting. "Oil-finish" paint, in which the last coat has, or should have, no turpentine, has a smooth, but, in these days of adulterated oil, not a glossy surface, which, however, can be washed without injury, and is much less subject to marking than a flatted coat. In the "china-gloss" finish the last coat is mixed with varnish; which may or may not be advantageous, according to the character of the varnish. When a poor, cheap varnish is used the paint is likely to be sticky in damp weather, and to turn yellow after a time; but, with good varnish, a china-gloss finish is very serviceable, being easily washed, and so hard that it is not readily marked. Some painters, instead of putting varnish into the last coat of paint, varnish the work after painting; but this is objectionable, as the varnish is apt to turn yellow.

Discoloration of paint.

Most housekeepers who have woodwork painted white to take care of find that the paint is disposed to turn yellow, sometimes as a whole, and sometimes in streaks and spots. This may proceed from either of two causes, or

from both combined. Where the trouble shows itself in streaks, or speckles, or in large rounded or oval spots, it is generally due to pitch in the wood. Pine wood, which is generally used for the best painted work, on account of its freedom from warping and shrinkage, contains a resinous sap, which is particularly abundant in the knots, but occurs also in streaks, and in small spots, scattered over a considerable surface. In whatever form it may be present, it will penetrate, in the course of a few months, through any number of coats of paint, producing yellow streaks and spots, unless it is covered with impervious varnish. Knots are often so full of pitch that even varnish will not keep it in, and the knot must be "killed" with lime, or cut out, and a new piece inserted, before varnishing; but ordinary streaks and specks can be satisfactorily treated by covering them with a thick coat of shellac varnish. As shellac varnish is expensive, most painters use as little of it as they can for covering the "knots, sap, and pitchy places" usually mentioned in the architect's specifications, and, in consequence, omit spots which make themselves visible later; so that the safest way is to require the pine woodwork to be varnished all over with shellac, to make sure that all the pitch is covered. Where this is demanded by the contract, it is usual to give the wood a light coat of paint, as a priming, before putting on the shellac. In this way the varnish can be put on more evenly, and

its effect in preventing the pitch from coming through is the same. Where no attempt, or an unsuccessful one, has been made to cover the knots and pitch at the first painting of the house, and the householder, displeased with the yellow and brown streaks in the woodwork, has made up his mind to have the whole repainted, it is advantageous, before doing so, to varnish the whole of the old work with shellac. If this is done, the paint will remain unstained by pitch for an indefinite period; but, if no varnish is put on, the stains will make their way through the new paint in a year or two, and the painter must be called in again.

White lead.

Stains of pitch or sap penetrate through either lead or zinc paint, but white lead, which is the pigment most commonly used, has the property of turning yellow in a dark room, whether there is anything to stain it or not. Zinc white is not subject to this change, and is therefore preferable, if it can be obtained pure, for interior work. Where woodwork painted with white lead has once turned yellow, nothing but repainting will restore it; but the yellowing can be delayed by keeping the rooms as light and sunny as possible. Tinted paint, which usually has a basis of white lead or zinc, behaves in the same manner as white, but the stains are, of course, less conspicuous.

Outside painting.

For outside painting, white lead is the most desirable of all pigments. Being exposed to the

light, it does not turn yellow, as it is likely to do inside the house, and it has the invaluable property of becoming "chalky" with age, and of clinging to the wood long after the oil with which it was originally mixed has been destroyed by the weather. The venders of inferior paints usually affect great scorn for old and chalky white lead, and often, if an opportunity offers itself, rub their hands over a bit of old white lead paint, and show, reproachfully, the white dust which it leaves on the skin; but, as a matter of fact, nearly any other pigment would have blistered off, leaving the wood bare, years before the white lead began to acquire a chalky character, the chalkiness of white lead being simply the manifestation of that persistent adherence to wood which is its most valuable quality. Yellow ochre, or "French ochre," as it is called at the paint shops, also clings tenaciously to wood, but it has, when mixed with modern linseed oil, a propensity for "mildewing," or turning black, where exposed to rain, which deprives it of much of its value for exterior painting.

Although white lead is thus the best pigment known for outside use, it is necessary, in order to take advantage of its valuable qualities, to get it pure; and this is not always an easy matter. Enormous quantities of chalk, baryta, and zinc are sold as white lead, with, and even without, an admixture of genuine lead. Two or three brands of paint, at least, are to be found in the

Adulterations of white lead.

market, in kegs, with the stencilled or printed inscription, "Warranted Strictly Pure White Lead," which do not contain even a trace of white lead; and many other brands contain little except chalk and baryta, with a certain proportion of zinc. The safest way for the householder, who has not at hand the materials for making a chemical test for pure white lead, is to buy the lead himself, and see that every keg is branded with the name of the National Lead Company. This company, although it ranks among the trusts, is entitled to the credit of having held out firmly against adulteration, and any unbroken package of white lead bearing its name is, unless its practice should change, filled with white lead only, pure and well made. As there is, naturally, a large profit in buying chalk and baryta at a few dollars a ton, and selling them as white lead at nine or ten cents a pound, the inexperienced buyer will be pursued with advice to purchase some brand "less expensive" than those controlled by the National Lead Company, but "just as good"; and, if he persists in his preference, will probably be offered something which, he will be told, is "made by the National Lead Company," and is "just the same as their regular brands," but, for some mysterious business reason, is sold without their name. The effect of a prospective profit of a hundred per cent or more in influencing a dealer's eloquence should be kept in mind in listening to these

tales; and, fortunately, the truth of them is easily tested, if necessary, by analysis of a sample of the goods.

Having procured some genuine white lead, the householder who wishes for good results from his painting should also buy linseed oil. The linseed oil of commerce is almost as extensively adulterated as the white lead, menhaden oil being sold for it in immense quantities. The easiest way of detecting serious adulteration is to smell a sample of the oil offered as linseed, first cold, rubbing it in the hand, and then by spreading a little on a paper or rag, and burning it. The smell of pure linseed oil is so characteristic that any considerable adulteration will be noticed; and, if necessary, a sample may be compared with the perfectly pure linseed oil put up in small bottles for artists. Linseed oil.

The cost of painters' materials is so small in comparison with that of the labor of putting them on, that it is far better economy to use oil and pigments, in the first instance, which will cling to the woodwork for half a generation, than, at a little smaller expense, to employ pigments which will wash off in a few years, or, what is worse, blister off, leaving patches of bare wood, which will show as defects through subsequent paintings. It is understood, of course, that a house is not necessarily white because it is painted with white lead, as the lead can be mixed with other colors. In general, however, the lighter

the color with which a house is painted, the more durable the paint will be, and the more comfortable the house itself will be, both in winter and summer, white paint having a surprising effect in reflecting the sun's rays in hot weather, and keeping the house behind it cool, as well as in preventing radiation of the heat of the house in winter.

Ready-
mixed
paints.

Some painters, and many more amateurs, instead of going to the trouble of mixing the thick pigment from the can or keg with oil to the proper consistency, and straining it, to remove bits of "paint skin" and other solid particles, use the "ready-mixed" paints, which are sold by dealers in all colors, and of all qualities. Some of these paints, although by no means all that claim to be, are made with good white lead, mixed with reasonably pure linseed oil, with or without drier, according to whether they are intended to dry quickly or not; but many varieties, which look bright and shining on the sample cards, contain water, often in large quantities. which is made to unite with the oil by the addition of silicate of soda, or some other strong alkali, which converts the oil into a sort of soap, soluble in water. Naturally, paints made with soap do not long resist the weather; but, as the business of selling water at the price of oil is very profitable, they are extensively used. In the western country, and even in the Mississippi Valley, the best of the ready-mixed paints stand well; but

on the seacoast, or within reach of the salt spray carried by storms far inland, nothing but materials known to be perfectly pure should be used.

For the outside of houses, particularly when shingled, stains of different sorts are much used, and, by their slight variations of color, give to the house a peculiarly picturesque and homelike character. They are, however, rather evanescent, and do little to protect the woodwork against weathering. What is called "natural creosote," a tarry oil, which gives a pleasant brown color, is probably the most enduring stain of the kind, and assists in preserving the wood from rotting. The lighter shades of creosote are mixed with pigments of brighter colors, which wash off more or less rapidly, according to their different characters, the creosote having little power of binding them to the wood. Other bright stains are said to be mixed with petroleum; and there are stains in the market which claim to have still a different vehicle, the nature of which is not revealed. Where stains are used, it is best to paint cornices, mouldings, finish around windows and doors, clapboards, corner-boards, and, in general, all planed work, with three coats of good paint, which will preserve it from warping and splitting in the sun; and to confine the stain to the shingles, which are not injured by sunshine. Sooner or later, the stain will be washed off the lower portion of the shingles by the rain, but it can be renewed at small expense.

Other
painting
materials.

Varnish.

In some parts of Europe outside woodwork is varnished, using a "spar varnish," which resists the weather, and the effect is very pretty. In our trying climate it is practically impossible to keep any varnish on woodwork directly exposed to rain and sun; but the more sheltered portions of a house, such as cornices, and the finish of piazzas, porches, and balconies, may be, and occasionally are, treated with varnish, with excellent results, particularly in localities remote from the seashore.

**Painting
plastered
walls.****Size colors.**

So far, we have considered only the painting of the woodwork of a house, but the plastered walls, and sometimes the ceilings, need paint of some kind, or other protection, not only to improve their appearance, but to prevent them from showing dirt and marks. The cheapest, and, in some respects, the best paints for this purpose, are those in which glue size is used as a medium, the glue being dissolved in hot water. Only enough glue is used to form, when cold, a soft jelly, which is easily broken up by stirring into a creamy liquid, with which pigments in dry powder are mixed. Ground whiting, or chalk, is generally used for white, and for the basis of all light tints, but ground plaster of Paris is said to have certain advantages over whiting. White lead and zinc are rarely, if ever, used in size, or fresco painting. As the lime in the plastered walls and ceilings which are usually treated in fresco destroys many colors, the range of avail-

able pigments is rather limited, but it is extensive enough for ordinary purposes. A great deal of money is spent in advertising "cold-water paint," which is simply size color in which the glue is made soluble, in various ways, in water at the ordinary temperature; but, except for the convenience of being able to thin the paint with cold water, the size is better in its normal condition. Very frequently alum, which has the effect of rendering glue or gelatine less soluble, is added to the size; and some painters put in also soap, and even linseed oil, to secure some fancied advantage. However made, size colors, notwithstanding all that is claimed for them by enthusiastic advertisers, are unsuitable for painting woodwork, owing to their total lack of the elasticity of oil paints; but, when well mixed, and well put on, nothing gives a more beautiful finish to a plastered surface, the paint drying perfectly free from gloss, and the colors generally having a peculiarly soft tone.

When badly mixed or put on, however, fresco painting is likely to give trouble in various ways. It is usual to brush a new wall or ceiling over with thin glue size as a preliminary to painting, in order to fill the pores, and prevent the plastering from absorbing the water unevenly from the paint; and, after the size is dry, the color is put on as rapidly as possible, in one coat. If the preliminary sizing has been imperfectly done, the absorption, or "suction," of the plastering will

show itself in uneven patches in the finished work. If the sizing is properly done, the finished painting may still be uneven, through insufficient mixing of the paint before it is put on. Where the preliminary sizing has been too heavy, or the paint is mixed with size either too strong or not strong enough, or if the plastered wall is old and greasy, the paint may come off, either in fine powder, or in little chips. In any of these cases, the only remedy is to wash the wall or ceiling off with hot water and a sponge, and paint it over again. It is not usually necessary to size it a second time, if the sizing was originally well done, as the washing does not remove the glue from the pores of the plastering. Even if the defect is a small one, the washing of the whole wall or ceiling with hot water is a necessary preliminary to treating it, as it is impossible to patch or retouch size color, the junction of the old and new work always showing as a dark, shining line. Fortunately, size and whiting are cheap, and the process of putting on the color is a very simple one, so that washing off and repainting, if the first attempts are unsuccessful, is not an expensive matter.

Oil-painted
walls.

Notwithstanding the beauty of size colors, the impossibility of retouching them successfully makes it desirable in houses of the better class, where washing off a wall or ceiling would involve the moving of much costly furniture, and perhaps endanger expensive floors and wood-

work, to paint the plastering in oil. For this purpose it must be sized, as it is even more necessary to check the "suction" of a wall to be afterward painted in oil than where size colors are used. Usually, the size, which may be either ordinary glue size or varnish, is put on as a first coat; but there are some advantages in putting on a coat of paint first, and the size over it. In any case, at least three coats of paint will be required, in addition to the size, to give a reasonably even surface. As ordinary oil paint is glossy enough to reflect the light at certain angles, every unevenness in a wall covered with it is revealed; so that it is usual to deaden the gloss of the last coat, either by mixing it with turpentine alone, or by going over the entire surface, while the paint is still wet and soft, with a stiff brush, which is touched to the surface so as to raise the paint in little waves. This "stippling" leaves the paint with a washable surface, and is for this reason to be preferred to "flattening" with turpentine, which, although it gives a pretty surface, leaves the wall very susceptible to marks of all kinds, which are not easily removed, since a "flattened" coat can hardly be washed without leaving streaks, and can be patched or retouched only with difficulty, as color mixed with turpentine alone dries with a dark edge, like colors mixed with size.

Flattening.

Stippling.

To the average householder, the conception of a room involves the idea of paper on the walls;

Wall-papers.

and wall-papers still form the mural decoration of the vast majority of houses. They have the advantage over paint that they do not show scratches and wear so quickly; that they are easily changed or renewed, and that they help to "furnish" a room otherwise, perhaps, bare, besides in many cases offering real artistic charm. On the other hand, some papers soon fade and look shabby; some contain very poisonous colors, which give off either deleterious dust or noxious vapors, or both; and all of them are put on with flour paste, which slowly putrefies, with the production of the acrid, musty emanations characteristic of old houses. In point of expense, there is not much to choose between painting the walls of a house, and papering them. Although some of the cheap wall-papers are very pretty, the cost of putting them on has advanced greatly within a few years, being often several times as much as that of the paper itself; so that, in general, a wall can be painted in size color more cheaply than it can be papered, even with the cheapest paper; while painting in oil costs somewhat more than papering with a cheap paper, but much less than papering of an expensive character.

Artistically, the choice between paper and paint depends upon several considerations. While walls simply painted unquestionably look bare in comparison with those covered with paper, this is sometimes an advantage, as in summer

cottages, to which they give a feeling of space and air, and in rooms containing a large amount of furniture, where they improve the effect of the furniture by affording a plain background, where a figured paper would produce a sense of wearisome confusion. Where pictures are to be hung, also, either a painted wall or a plain paper is much to be preferred to a figured paper. Very frequently, figured and plain papers, or figured papers and paint, are used together with good effect. The old William Morris system of papering the wall of a room to a height of about four feet from the floor, finishing at that point with a moulding or a black line; then painting with a plain color from this level to within about sixteen inches of the ceiling, and finishing with a figured paper frieze, so that the pictures come against a plain background, while the upper and lower divisions of the wall are decorated, can hardly be improved upon, if the colors of paper and paint are judiciously selected, for living-rooms of moderate size, particularly if they are irregular in shape.

Morris
system.

The papering of ceilings, once almost universal in good houses, is now out of fashion, the close, bandbox-like effect of a room with the walls and ceilings entirely covered with figured paper having led to its abandonment; but a figured ceiling does not necessarily imply a figured wall; and, as the ceiling is the portion of the room best suited for decoration, being always unobstructed

Papered
ceilings

and visible through its whole extent, it is quite possible that a new system might be evolved, with plain walls, and ceilings decorated with the little gold stars or butterflies of the earlier ceiling-papers, or with more ambitious compositions of birds or cherubs against a blue sky, which would, with well-selected colors, be quite charming. As a ceiling presents an unbroken surface, there would be little difficulty in reproducing in this way the French and Italian painted ceilings, at a moderate expense.

Cartridge-paper.

Where a wall of plain color is desired, either with or without figured friezes or dados, cartridge-paper is much used, partly, no doubt, in consequence of an impression that it is washable, like oil paint. Some of the more expensive varieties of cartridge-paper can be wiped with a damp cloth without injury, but rubbing with crumbs of stale bread is a much safer operation, even with these, and the cheap cartridge-papers will not bear anything more.

Besides the cartridge-papers, plain papers of other sorts can be had, including some very expensive varieties, painted in oil, or even covered with silk.

Colors in wall-papers.

As the fading, or changing color, of wall-papers detracts very much from their beauty, it would be desirable to know what colors are most subject to change; but this knowledge appears to be denied, even to the manufacturers themselves, who can seldom speak with confidence on the

subject. Yellows are, perhaps, the most liable to change color, either by fading or turning brown, and reds next ; and, in general, papers in which all the colors are light show the effects of fading the least.

Poisonous colors are more easily detected than those which will fade. It is a common idea that only the green in wall-papers is poisonous, or, at least, arsenical ; but arsenic is found in many other colors, particularly in pinks and purples, and even in browns, the arsenical pigments giving a freshness and delicacy to the tints with which they are mixed which makes them popular among manufacturers. American wall-paper manufacturers, as a rule, conscientiously avoid arsenical colors, and the use of them is forbidden by law in France, at least for wall-papers for domestic consumption ; but those manufactured in France for export are said to pass the inspector's criticism more easily, and to contain arsenic in many cases. The worst of all wall-papers in this respect are, however, the Japanese, some varieties of which are so loaded with arsenic as to affect the paper-hangers who put them on. Not only is the poison found in the colors, but the bronze powders, which the Japanese use very freely in printing their papers, are often highly arsenical. These bronze powders are readily brushed from the paper, while the souring and decay of the paste with which the paper is put on causes chemical action, which may help in diffusing arsenical fumes ; so that, to per-

Poisonous
colors.

Japanese
wall-papers

sons sensitive to arsenical poisoning, it may be even dangerous to sleep regularly in a room papered with such paper. Nor is arsenic the only poison found in wall-papers, mercury, which is often present, being little less deleterious.

Testing
wall-papers
for arsenic.

For thorough testing of papers for both arsenic and mercury a chemist should be employed; but arsenic alone can be detected by the amateur without difficulty. For this purpose, some tubes of glass, a quarter of an inch or so in diameter, inside, and four or five inches long, should be prepared by heating one end in a lamp or gas flame, drawing it out, and melting it together. In each tube should be put some bits of the paper to be tested, and the tube over them should be filled for an inch or so with chips of charcoal, or charred wood. To make the test, the portion of the tube containing the charcoal chips must first be held in a flame, until they begin to glow. Then the end of the tube, containing the bits of paper, is heated, until the paper is entirely consumed. The burning of the paper volatilizes any compounds of arsenic or antimony that may be attached to it; and the fumes, in passing through the red-hot charcoal chips, are reduced, and deposit on the cool part of the tube, above the charcoal, a black, metallic ring, which may be either of antimony or arsenic. When all the tests desired have been made, the tubes may be broken, near the deposited ring, and immersed in a solution of ordinary bleaching-powder, or

chloride of lime, such as is sold in little cans at the grocery stores as a disinfectant. If the metallic ring is dissolved by the chloride of lime solution, it consists of arsenic. If it is not dissolved, it may consist of antimony, or, possibly, of some organic compound, but not of arsenic. After a little experience, the peculiar smell of the arsenical fumes, closely resembling the breath of a person who has just breakfasted on onions, will be recognized as they issue from the heated tube, before the deposited ring is tested with the chloride of lime solution.

In a well-ventilated modern house, with plenty of fireplaces to give a current of air, there is not usually much annoyance from the smell caused by the decomposition of the paste used for putting on wall-papers; but in the houses of the poor, where there is little or no ventilation, and where, to save the expense of taking off the old paper, when renewals are necessary, the walls are frequently covered with several layers, one above another, of alternate paste and paper, the odor is often extremely unpleasant, and probably injurious to the inmates. To avoid, as far as possible, anything of this kind, new paper should never be put on a wall without cleaning the old paper entirely off, down to the bare plaster. There will then be only one stratum of paste on the wall; and, as that will be fresh, it is not likely to give trouble, at least for many years, unless it should get wet in some way.

Paste for
wall-papers.

A few careful owners of tenements for the poor require corrosive sublimate, or mercuric chloride, to be added to the paste used for putting on papers. This, being very poisonous, prevents vermin from burrowing under the paper, and eating the paste, as they are fond of doing; and, being one of the most powerful antiseptics known, it preserves the paste from decomposition. A very small quantity of the corrosive sublimate, well mixed with a pailful of paste, is sufficient for both these purposes; and, not being volatile at ordinary temperatures, it does not appear to have any injurious influence on the air of the room.

Cleaning
paint and
paper.

In cleaning paint and paper it is desirable to know something of the character of the paint or paper to be treated. Size or fresco color cannot be touched with water, which would leave indelible spots; but it can be cleaned with bread crumbs. Stale bread must be used, as fresh bread would stick to the surface; and the crust must be carefully cut off, so that there may be no hard particles to scratch the paint. The remainder is then broken up, and rubbed over the paint with the hands. The crumbs, as they fall on the floor, may be caught in a paper and used over again, but, as soon as they begin to dry and harden, they must be thrown away, so that the paint may not be scratched. With care, fresco color can be very well cleaned in this way. Wall-papers may be cleaned in the same

manner, even where the colors are very delicate. With the plain dyed or ingrain papers, generally classed together as cartridge-paper, Indian meal may be used instead of bread crumbs, but it has no advantage over the bread crumbs, except in being cheaper.

Oil paint should be capable of being washed with soap and water, but the success of the washing depends on the way in which it is done, as well as on the character of the paint. Flatted paint, in which the last coat is mixed partially or wholly with turpentine, is very delicate, and is not only easily soiled, but is washed with great difficulty. The indispensable requisite of success in washing such paint is never to allow soapy water to dry on the surface, as it will make ineffaceable streaks in doing so. It is necessary, therefore, in washing, to apply the water, mixed with good soap, or some mild alkali, such as soda, or saleratus, or ammonia, or pearline, with a sponge, followed immediately by a soft cloth, with which all trace of the water must be wiped off, before it has time to dry, even at the edges. In this way even a flatted surface can be successfully cleaned; and, although stippled, or "egg-shell," or "china-gloss" surfaces are much less delicate than those made with turpentine, it is desirable, even with them, to wipe off the washing water before it begins to dry. Gritty materials, such as pumice-stone soap, "sapolio," or sand soap, should not

Washing oil
paint.

be used in cleaning paint if it can be avoided. Some spots and stains, undoubtedly, cannot be removed without their aid; but they take off the paint, as well as the stain, and, after a few applications, the wood or plastering is left bare.

Cleaning
varnished
surfaces.

Varnished surfaces should, in general, never be washed. The best varnishes are nearly waterproof; but, even with them, washing dims the surface; and, with inferior varnishes, water causes white or yellow spots. It is, therefore, safest, in all cases, to use only a dampened cloth for cleaning, with or without soap, according to the character of the dirt to be removed, rubbing the varnish at once perfectly dry. Woodwork finished in wax bears washing better than a varnished surface; for, although water immediately turns the wax white, rubbing with a hot woollen cloth will restore it; or, if the wax has been nearly washed off, a little fresh wax, applied to the bare spot, will make it look as well as ever.

Defects in
paint.

Painted or varnished woodwork and plastering, both inside and outside, are liable to defects, which may sometimes be remedied without doing the work over. Considering first outside woodwork, it will often be observed that the paint, especially on the sunny side of a house, is disposed to blister. This may result from using inferior paint, containing too little white lead or yellow ochre to make it cling to the wood; or, even where good materials have been used, it may occur in consequence of painting over

Blisters.

woodwork not thoroughly dried, or superficially moistened from rain, or from frost. As the paint is comparatively impervious to moisture, the vapors from any water that may be enclosed under it, not being able to escape, expand, and push up in blisters the coating under which they are imprisoned. For this reason it is best, in making contracts for a new house, to require the builder to put only two coats of paint on the outside. Although two coats of paint make a rather thin coating on new wood, the very thinness of the coating gives an opportunity for moisture underneath to evaporate, without throwing off the paint; and when the house is two or three years old, and the woodwork has become thoroughly dried, a third coat can be put on, with the prospect that it will remain in place; while, if three coats are put on at the beginning, before thorough seasoning of the wood, the thick covering so formed is very likely to blister.

When blisters have once formed, little or nothing can be done except to leave them until the time comes for sandpapering them off, and repainting. If they are few in number, the bare places which they leave can be retouched before putting on the final coat, so that all may be covered equally; but, if they are very numerous, nothing but burning or sandpapering the paint entirely off will restore a smooth surface.

Similar retouching is necessary, even with good paint, where rain and snow have worn the paint

off the most exposed points, before the work can be evenly covered ; and, where the house has been neglected, and the paint is much worn, it is often cheaper to apply two entire coats, without re-touching, than to retouch extensively, in the hope of making a single coat answer.

Outside varnish cannot be retouched, or properly covered with a fresh coat ; and the only thing to be done, when a varnished door becomes shabby, is to scrape off the old varnish, or remove it with oxalic acid, and revarnish.

Sashes.

In any repainting of a house, the outside of the sashes should be particularly looked to. Most glazing is done by the sash-maker, who sublets this part to the lowest bidder ; and the lowest bidder contrives to make a profit on the job by setting the glass with putty made with marble dust and kerosene, instead of linseed oil and whiting, trusting to the three coats of paint which the painter will put over the putty to hold it in place. The paint has, in fact, this effect for a few months ; after which the putty begins to curl away from the glass and fall off, carrying the paint with it, and leaving the wood bare. As rain-water, running over the glass, and lodging on the sash-bars, will soon rot them out, it is necessary to reputty the glass at once ; and to do this properly, the sash-bars must be painted, with good linseed-oil paint, so that the wood may not absorb the oil from the putty in contact with it, and prevent its adhesion, and

good putty, of pure linseed oil and whiting, applied, allowed to harden, and painted three coats. Thus treated, the putty of the sash will last as long as the woodwork itself, becoming almost as hard as stone, and clinging tightly, both to the glass and the wood.

Inside painting is less liable than outside painting to blister, but it sometimes shows this defect, particularly about a fireplace; and the old-fashioned boiled-oil paint, being more impervious, is more liable to it than the raw oil or flatted paint of the present day. In any case, sand-papering and repainting form the only remedy. Where white inside paint turns yellow, from the use of white lead in rooms insufficiently lighted, zinc white should be used in repainting; and, if the yellow appears in streaks or spots, a coat of shellac before the repainting will be useful. Occasionally, a cheap imitation of enamel work is made by painting with two or three coats of ordinary white paint, and varnishing the paint. This method answers for carriage-painting, where first-class varnishes are used over black paint; but it is entirely unsuitable for white or ivory finish, the varnish soon darkening, and showing uneven yellow streaks over the white ground, which nothing but repainting will conceal.

Paint on plastered walls is very apt to show uneven streaks, where the plastering underneath is particularly absorbent, or has not been properly sized; and, when cracks in the plastering are cut

out and patched before painting, they remain visible, even through several coats of paint, as dead streaks, which are particularly conspicuous in work with an "oil finish." There is, apparently, no remedy for this trouble, except frequent repainting, the streaks gradually disappearing under multiplied coats.

Glass and
glazing.

As, for some reason, painters are usually intrusted with the work of setting glass, the care of glass may be considered in connection with that of paint.

Plate-glass.

For those who can afford it, no window-glass compares in beauty with polished plate. Not only is it perfectly flat and even, so that objects appear through it without distortion, but it is thick and strong, so that it can be used in large sheets without much fear of breakage; and it keeps out the cold far more effectually than ordinary sheet-glass. Plate-glass is, however, very heavy, so that sashes glazed with it, if of large size, are not easily managed; and it is soft, and much more readily scratched than common glass.

Sheet-glass.

Of the common, or sheet-glass, there are two sorts, known as "single-thick" and "double-thick"; the former being about one-sixteenth of an inch in thickness, and the latter one-eighth of an inch. Sheet-glass is made by blowing out a lump of melted glass into a hollow cylinder, which, while hot and soft, is split through the middle, and allowed to flatten out on a stone or iron table. The thin single-thick glass lends itself better to

this operation, and makes flatter sheets than the double-thick ; so that single-thick glass is not only cheaper, but is flatter, and more free from defects, than double-thick of the same quality, and is, for that reason, generally used in houses built for sale. It is, however, very fragile, and presents little resistance to the cold of the outside air, so that double-thick is always to be preferred. Although it costs very little more than the single-thick glass, it is more than four times as strong, and is much more efficient as a protection against the cold in winter.

The glass that our grandfathers used in their windows was subject to a bluish discoloration from exposure to the weather ; but modern glass is better made, and is not likely to show any dimness which does not come from extraneous and removable dirt. To remove this dirt, the professional glass-cleaners use a mixture of soap and water and ground chalk, or whiting. This is rubbed over the glass with a rag or sponge, and allowed to dry ; and the whiting, which of course remains on the glass, is rubbed off later with dry cloths. This process is much more rapid than that which consists in washing with several changes of water, and answers quite as well.

CHAPTER XIII

KEEPING A HOUSE IN REPAIR

To none of the concerns of life is the proverb about "a stitch in time" more applicable than to the matter of keeping a building in repair. The little leak, if not attended to, soon becomes a large one; a spot of dry-rot in a timber soon infects the whole, and the splitting of a shingle, or the rusting of a piece of tin in a roof, by admitting water, may be the source of extensive decay.

A good lesson on the results of neglect may be derived from the inspection of one of the many houses to be found in every neighborhood which have fallen into the hands of mortgagees, or trustees, or careless landlords of other kinds. Visiting one of these structures, even though it may not have been built many years, we shall be likely to observe, as we examine the outside, that the chimneys bend slightly toward the northeast, owing to the washing out of the mortar in the joints of the brickwork by rain, aided by the disintegrating action of frost. Very likely some of the bricks at the top of the chimneys will have become entirely detached, so that they have been blown off, either dropping into a flue and

choking it, or falling on the roof below, breaking the slates or shingles, or making a hole in the tin or composition of a flat roof. Possibly the metal flashing at the junction of the chimney with the roof will be found to have been blown out of place by the wind, or, by the rusting of a few nails, a shingle may have slipped down here and there, or the shingles in the valleys may be evidently decayed. In any of these cases there will have been a bad leak in the roof, and the plastering inside at that point will be found stained, if not entirely detached from the laths.

Looking at the foot of the roof, we shall probably find places where the joints of the gutter have rotted, allowing streams of water to run down the wall below after every shower, washing off the paint, and showing the black and decaying wood. A little below this point we shall observe that the blinds, instead of being rectangular, have sagged into a rhomboidal shape, and will no longer close properly, while some of the slats, forced out of place by the distortion of the frame which holds them, have disappeared. In some cases, also, the fasts which hold the blind, either open or closed, have come out, and the blind, left at the mercy of the wind, has slammed against the window, breaking the glass. The entrance porch is provided with a gutter, and a conductor, to carry off the rain-water, the latter having originally had a "shoe" at the foot, to lead what little water would come from the porch

roof harmlessly out upon the grass ; but the shoe has become detached, probably by the weight of ice in it in winter, and the rain-water, being discharged just at the corner of the porch, has soaked the foundation, besides blowing and splashing over the floor, so that we find the sill of the porch so badly decayed that it will hardly bear our weight ; while a portion of the floor boarding has already fallen through.

Entering the house, we find the ceilings and floors stained in various places, where rain-water has reached them from a leak in the roof, or a broken window ; the hard-wood floors of the first-story rooms, having swelled, partly from water blown in over them, and partly from the general dampness of the house, have "huffed up," as the carpenters say, in ridges, at the most exposed points ; the wall-papers show mouldy streaks, from similar causes ; and the concrete floor of the cellar is disintegrated on top, through the freezing of water which has blown in during a winter storm, from a basement window, the fastening of which has disappeared. If the house has been for a long time neglected, still worse disorders will probably be apparent, such as ceilings fallen, floors out of level, and walls and partitions distorted, through the rotting of sills and girders ; but it is not necessary here to consider the more serious cases.

Nothing is more discouraging to a householder than to find himself obliged to deal with an

accumulation of such troubles at once, although any one of them separately might be of little importance; and it is the part of wisdom, not only to prevent them from accumulating, but to reduce the seriousness of each, by timely application, in every case, of the proper remedy.

Of the way in which leaks in roofs are caused and prevented we have already spoken. The ordinary householder does not often possess materials and apparatus for putting on new flashings, or repairing shingle or slate roofs, or gutters and conductors; but a leak may often be temporarily stopped, until a roofer can be sent for, with a bit of tarred felt, or a little roofing pitch, or elastic cement, and it is very desirable, particularly for large establishments in the country, to keep a supply of these materials on hand.

The repairing of a chimney is also a difficult matter for an amateur; but the householder can at least watch his chimneys, and send for the mason as soon as he sees that the joints at the top are losing their mortar. By doing this, the relaying in cement of a few bricks at the top of the chimney, and the repointing of the rest with cement, inserted into the joints, will be sufficient to keep in good order a chimney which, if left to itself a few months longer, might have to be taken down to the roof, and rebuilt, even if it did not fall, wholly or partially, in the meantime.

In places remote from professional masons, a barrel of Portland cement will be found a very

useful addition to the supplies of the establishment. With its aid loose bricks, either inside or outside the house, can be permanently set in place ; concrete floors can be repaired, stone walls pointed, and even greenhouse pipes, which have begun to leak at the joints, may be made tight. It is not necessary to use any sand or lime with the cement. On the contrary, work done with clear cement is stronger than that in which any mixture is used ; and although Portland cement at \$1.50 or so a barrel is more expensive material than sand, the difference is a mere trifle where repairs are concerned ; and the saving made by employing home talent on such work, instead of sending for a professional mason, will soon pay for many barrels of cement. It may be observed, for the benefit of the owners of country estates who find that the repairs to their cellar walls and fences form an important item in their annual expenses, that the Italian laborers, who are becoming very numerous in the Eastern States, are almost universally tolerably accomplished masons. As farm buildings in their own country, even to the pigsties, are always of stone, they are accustomed from childhood to the use of a trowel ; and the Italian traditions of bonding the stones or bricks, and of laying each piece in a bed of mortar prepared for it, are admirable. For laying face-brick or cut stone, a skilled workman is, of course, required ; but, for the rough masonry of a farm, most Italian laborers are well qualified.

As the disorders of exterior woodwork generally proceed from decay, it is hardly possible to take too great precautions against exposing timber of any sort to alternations of dryness and moisture. If to these are added a close atmosphere, such as exists under the boards of a floor, decay may proceed so rapidly as to destroy new timbers in a few months. The best prophylactic, as the doctors say, against decay is a good circulation of air; and to keep piazza and porch floors from rotting, not only should rain-water from conductors be carried to a distance, but the floor boards should be laid a quarter of an inch apart, and the outside should be finished with lattice work, so that air can at all times circulate freely about them. If this is done, the inevitable surface wetting of the floor by rain will do no injury, as the water does not soak in far, and soon evaporates.

The sagging of blinds, which is extremely common, but always gives a slatternly, dilapidated look to a house, is due, not to decay, but to shrinkage, which causes the wooden pin driven through the corners of the frame of the blind to become loose; and as the friction of this pin is, ordinarily, the only thing that keeps the corners rigid, there is nothing to prevent them, when the pin shrinks, from assuming other angles, as gravity may dictate. After the distortion has become so serious that the slats have fallen out, it is hardly worth while to try to correct it, as blinds

Sagging of
blinds.

are cheap, and new slats are not easily made by hand to take the places of the old ones that may have been lost; but, until it has reached this point, it may be readily and effectually corrected by taking off the blind, pushing the corners back to the proper right angle, and fixing them there by screwing on the face of the blind, at the corners, iron angles which are made for the purpose, and can be obtained from any large hardware dealer for a few cents each. As they are stamped out of heavy steel plate, they are very strong; and as the angle cannot be distorted, after they are once firmly screwed on, without breaking them, they cure effectually the disposition of the blind to sag. For small blinds, one angle-iron is sufficient to maintain all the four corners indefinitely in their proper position, on the principle that if one angle of a parallelogram is a right angle, all the others must be right angles; but, for blinds of the usual size, it is better to use two, as the strain on the screws of a single one is very severe. In and about New York, blind hinges can sometimes be found, which comprise an angle-iron of this kind; but they are unknown in New England, where the hinges are always put on the back of the blind, and a separate angle-iron must be used for the face. Besides setting up and securing the corners, the hinges and fastenings of blinds need occasional inspection, as a broken hinge, or a missing fastening, means violent slamming in the next storm, which

will probably break the blind, and very possibly the window also.

The dilapidations which follow neglect in the inside of a house usually involve more expense in repairing than those which make themselves manifest on the outside; so that the first indication that anything is out of order should be investigated, and a remedy applied at once. Settlements from decay, or from the shrinkage or bending of timbers, or the failure of foundations, have already been treated of, and it is only necessary to add that they should be attended to immediately. Apart from these structural difficulties, the most common source of interior troubles is water. This may come from a burst or leaky pipe, or fixture, and will, in that case, require to be treated by a plumber, unless the householder possesses courage and skill enough to deal with it himself; or, it may come from rain, admitted through a leaky roof, or an open or broken window. Under any circumstances the leak should be immediately found and stopped, as continued or repeated wetting will bring down ceilings, and stain floors irretrievably, besides, in many cases, swelling the boards, so as to force them up from the beams, causing irregularities of surface which are not easily remedied.

For the householder who has not glaziers at hand it is of importance to know how to cut and set a light ~~of~~ glass on occasion, as it often happens that a broken pane, unless quickly repaired,

Setting
glass.

may give serious trouble. Cheap glass-cutters, the cutting part of which consists of a wheel of hardened steel, may be bought for 15 or 20 cents; and there are people who can cut a piece of glass with a red-hot poker, or a string dipped in alcohol; but a good glazier's diamond can be bought at the large hardware stores, or the painters' supply houses, for about \$4.00, and will soon save its cost by the superiority of its work; as, with its help, not only window-panes, but small pieces of glass, for framing pictures, making microscope slides, and a multitude of other purposes, can be cut with precision, and without the waste from breakage which commonly attends the use of the cheap cutters. It is not at all difficult to learn by trial how to use a glazier's diamond. Very little pressure is necessary; and, after the cut is once started, it is readily guided.

It is said to be a rule of the glaziers' unions that any member who may be called to replace a broken or cracked pane of glass must begin his labors by smashing the old pane into small splinters, before he sets the new one, so as to prevent any person from utilizing the pieces of the old pane by cutting them into smaller ones. As a pane of window-glass of ordinary quality often costs \$1.50 to \$2.00 the advantage to the householder of being able to cut and set his own glass, without having pieces destroyed that might be utilized elsewhere, is obvious.

Supposing a window-pane to need replacing, the first step in doing so is to ascertain the size of the glass required for the purpose. Usually, the sash-bars are "rebated" out three-sixteenths of an inch to receive the glass, so that the new pane required will be three-eighths of an inch wider than the "sight size," or clear dimensions, of the sash in which it is to be set. In the case of very large lights, the rebate may occasionally be deeper than this; but, if so, this will usually be shown by the moulding on the sash-bar

(Fig. 31) which occupies the same space as the rebate; so that the distances between the flat portions of the sash-bars give correctly the size of glass required; or the size may be measured on the outside of the sash, where, of course, the depth of the rebate is visible. Usually, in order to avoid waste of glass, sashes are made so as to take glass of sizes measured by even inches; but this is not an invariable rule.

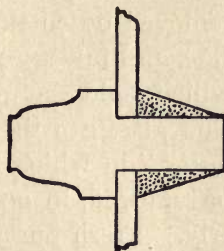

FIG. 31.

The proper dimensions having been ascertained, a pane may be cut from any spare pieces at hand. For amateurs, it is convenient to mark the outline of the pane required on a piece of paper, and put the glass over it, guiding the diamond with a ruler. After each cut is made, the

Setting
glass.

Cutting
glass.

glass may be separated neatly by putting the piece on a board, or table, with the line of the cut exactly over the edge of the board, and trying to bend the glass over the edge. This will cause it to break smoothly on the required line. Evidently, care should be taken not to cut the glass too large. It may be a fraction of an inch too small without harm, but, if cut too large, it is difficult to trim off the excess.

The new pane having been cut, the old one is removed by cutting away the putty on the outside, and taking out the triangular "tin tacks" which hold the glass in place, under the putty. The glass can then be taken out; but the "back putty," in which the glass was bedded, must also be removed, in order to bed the new piece properly. Fresh putty is then to be put in place of the old bedding-putty, the new piece of glass pressed firmly into place, the tacks inserted in their old positions, and lightly hammered, or driven in with the putty-knife, and the outside putty put on, smoothing it, when the work is completed, with the putty-knife. After hardening a day or two, the putty may be painted to match the other portions of the window. In the case of large lights, it is most convenient for glazing to take out the sash altogether, which can easily be done by taking out the screws from the "inside beads," or strips which line the sides and top of the window, inside, removing the beads, and swinging the sash in far enough to allow the

cords which hold the weights to be reached and detached. After detaching, they must be knotted again, to prevent them from being drawn over the pulleys into the weight boxes. If the broken pane is in the upper sash, it will be necessary, after removing the inside beads, to take out also the "parting bead," or slip of wood which keeps the upper and lower sash apart. This is simply inserted into a groove, and can be readily taken out and replaced. The upper sash, when the parting bead is out, can be swung into the room and detached. After freeing them from the weight lines, the sashes may be laid on a table, or bench, fitted with new glass, and put in place again, the beads being replaced to hold all secure.

Where a window cord is broken, or has escaped from the hands in removing a sash, the trouble may generally be remedied by taking off the inside beads, and removing the screw, or screws, which will be found under them, near the bottom of the frame. These screws hold in place a portion of the frame, which, on being released, can be taken out, disclosing a "pocket," in which one or two weights can be dimly seen. There is usually a pocket on each side of the window, giving access to all the weights, of which each sash has two, one on each side. By putting the hand through the opening any weight can be taken out, a broken cord detached, and a fresh one put in. For the latter purpose the cord

Broken window cords.

should first be attached to the sash requiring it, either by means of a knot, or of a metal anchor, inserted in a hollow provided for it on the side of the sash. The other end of the cord is then to be passed over its appropriate pulley at the top of the frame, and let down, inside the weight box, until it can be reached with the hand, pulled out, and tied to the weight. The sash, after the cord is passed over the pulley into the weight box, should be raised to its full height, and held there with a stick or other support, while the cord is being tied. The cord, which is usually tied to the loop of the weight with several knots, to prevent slipping, should be just long enough to allow the weight to swing clear of the bottom of the weight box while the sash is raised to its fullest extent. If it is shorter, the top of the weight may, when the sash is pulled down, be drawn against the pulley, breaking the cord; and, if it is longer, the bottom of the weight will rest on the bottom of the weight box before the sash is thrown up to its fullest extent. This fault, which is very common, and is produced by the gradual stretching of the cord, or yielding of the knots, as well as by carelessness in the original adjustment, is most annoying when it occurs in connection with the upper sash, as it shows itself by the refusal of this sash to ascend to its proper place; so that, in order to lock the window, it is necessary to push up the upper sash with a stick or with the hands, while

Stretched
window
cords.

it is being locked. As the weight of the upper sash, if not counterbalanced by the sash-weights hanging free, strains the sash-lock severely, the pockets should be opened, the weights of the upper sash, which are those nearest the outside of the window, taken out, and the cords shortened; the sash being held up meanwhile with a stick, that it may not, when relieved of the weights, fall on the head of the operator.

It occasionally happens, particularly with mullioned windows, that the cords and weights become so entangled that they cannot be brought into order from the pocket. In this case it may be necessary to take off the architrave, or interior trim of the window, which will in frame houses expose the whole length of the weight box. The architrave is firmly nailed at one edge to the window-frame, and at the other to a "ground," and unless taken off with care, it is likely to be marred. In order to remove it, the inside bead of the window is first to be taken off. This will show the edge of the architrave where it is nailed to the frame. As this joint is covered under ordinary circumstances by the inside bead, a strong screw-driver may be used to separate the architrave from the frame. Care should be taken to keep the joint at the top and bottom of the architrave, where it meets other portions of the trim, from being damaged; and, after one edge is separated, the other may be reached by the screw-driver from the inside and separated from

Twisted window cords.

the "ground" without making any marks which will be visible on the outside. After the necessary work has been accomplished, the architrave may be put back, interposing a piece of board between it and the hammer which will probably be needed to get it into its place. Even with the greatest care, the putty over the heads of the nails in the architrave is likely to fall out, and some small scratches are, perhaps, inevitable; but such defects are not very noticeable, and are easily remedied if necessary.

If the pulleys, cords, and weights are kept in good order, a window is not likely to give trouble for many years. The parting beads sometimes warp and spring out of place, but they can be secured by a screw at the foot, driven into the sill so as not to interfere with the removal of the bead when required. The sashes also shrink slightly in one direction, and the inside beads in the other, so that a sash originally fitted tightly may give annoyance by rattling in windy weather. It is now common to put on inside beads with screws passing through brass sockets with slotted holes, so that the screws can be relaxed, the beads pushed up, and the screws tightened again in a few minutes. In this way the sashes can be perfectly adjusted at any time, so as neither to bind nor rattle; and this is, probably, the best and cheapest way of meeting the difficulty; but other devices, such as rubber wheels, which are screwed to the beads, pressing on the sash, or

Rattling
windows.

strips of rubber set in wood or metal moulding, are sometimes used.

Sashes that rattle because they are too loose are more common than those that are too tightly fitted, but the latter often occur. With adjustable sockets and screws on the inside beads, the sticking is usually quickly remedied; and such as may remain is generally cured by rubbing the grooves in the frame in which the sashes slide with paraffine or with common hard soap. The latter is probably quite equal to the paraffine as a lubricant for wood; but, not being waterproof, it does not last so long.

Sash-fasts, which are indispensable as a protection against burglars, often show a disposition to come out. They are usually packed with screws far too short for security; and as they furnish excellent examples of the power of an inclined plane, it is not surprising that, when the sashes do not quite meet in closing, owing to the presence of ice, or gravel, or other foreign substance under the bottom of the lower sash, or between the upper sash and the top of the frame, the forcible closing of the sash-fast, as it must either crush the obstruction, or pull out the screws, usually produces the latter result. If people, before locking a window, would see that the "meeting-rails" came evenly together, and if they did not do so, would raise the lower sash and brush away everything sticking to the edge of the sash, or lying on the sill under it, sash-fasts

would not get loose ; but, as this is too much to expect of human nature, they must occasionally be reset, with longer screws.

The faults
of doors.

Doors share some of the faults of windows, besides having others of their own. Among the former is a disposition to stick in damp weather, owing partly to the softening of the paint or varnish on them by the dampness, and partly to the swelling of the wood, by absorption of moisture. In this latter respect there is a great difference between doors of various woods. Whitewood is, perhaps, the worst wood in this respect. Being of a spongy texture, doors made of it will often swell in the damp days of summer, so that it is almost impossible to open them, and will shrink again in winter, when the air of the house is dry, so that the bolts of the lock will hardly catch ; and these variations are repeated every season, whitewood never losing its susceptibility to the effects of moist and dry air. The ordinary remedy for the sticking of doors, which consists in taking off the hinges, planing the back edge of the door, and putting the hinge on again, must, therefore, be applied with caution to whitewood doors ; for, if they are made small enough to shut easily in the dog-days, they will often be so small in winter that they will not stay shut. Pine doors are the best in common use in this respect, as pine shrinks less than any other wood, except California redwood, and, when once dried, has very little tendency to

absorb moisture again. The so-called hard-wood doors, which really consist of veneers, from one-eighth to one-quarter of an inch thick, of oak, mahogany, cherry, or ash, glued to a pine core, behave like doors of solid pine; and, if properly fitted in the first place, with one-eighth of an inch free space all around, are not likely either to shrink or swell enough to give trouble.

They may, however, stick from other causes. Very frequently the hinges of doors are too light, or the screws not long enough, so that they yield slightly under the powerful leverage of a heavy door, letting the top of the door fall forward sufficiently to bring the upper corner in contact with the frame, and the lower corner with the threshold. Then the door binds, and a carpenter is sent for, who usually planes off the corners a little, but without doing anything to strengthen the hinges, or the screws, which continue to yield until the door again binds, when the process is repeated. The planing away of the corners of the door destroys its rectangular shape, so that it can never again be made to fit neatly in its frame; and it is far better, instead of "easing" it in this way, to put on heavier hinges, with longer screws, or to put an additional hinge in the middle of the door, so that no sagging can take place after the screws are once driven firmly home. All doors more than seven feet high should have three hinges in any case; and solid bronze or brass hinges, if used, should have steel

Sagging of doors.

bushings, as the soft metal will otherwise soon wear away, and let the door sag.

Even when the door is properly supported, it may bind, through settlements or shrinkage in the partition, which distort the frame of the door. In the framing of wooden houses it is not unusual to see the partition stud on one side of a door opening standing on a girder or partition cap under the floor, while the stud on the other side of the opening stands on the top of the floor. As the floor beams shrink, the latter stud descends with them, often a quarter of an inch or more, while the stud which rests on the support below keeps its place, and the door-frame is, in consequence, distorted quite sufficiently to make the door bind against it. In this case, nothing can be done except to plane off the door until its upper edge is again parallel with the frame; and as the movement of the frame carries with it the striking-plate of the lock, while the lock itself, attached to the door, remains in place, there is usually difficulty in locking or latching the door, and the holes in the striking-plate must be filed out.

The locks and knobs of doors often give trouble, independent of any settlement. Most locks have certain portions of the interior mechanism of cast iron, which is easily broken, and the fragments, in such a case, often fall down so as to prevent the key from being turned. If this should happen after the door is locked, it may

be necessary to cut the bolt entirely off by means of a thin, flat file, with teeth only on the edges, inserted into the space between the door and the frame, before the door can be released. The mortise bolts which are set in the thickness of the door, with a knob or other handle outside for operating them, are liable to similar accidents, which must be treated in the same way. Knobs, unless they are so fragile as to break, give most annoyance by coming off, through the falling out of the screw which holds them upon their spindle. For some reason, these screws are generally so loosely fitted that they shake out of place in using the knob, and unless the householder is prudent enough to go about occasionally with a screw-driver, and tighten those that are loose, they are likely to come out altogether, and the knob then pulls out of the door. Screws of the proper size and shape can be had in bronze, brass, and iron, at the hardware stores, and it is well to have some on hand to replace losses, so that the knobs may be kept at all times in condition for use.

The door-knob itself will often require attention. The most satisfactory material is bronze, in what is called "statuary finish." This is a dark brown which never changes, except where projecting portions are polished by the hands. The bright bronze is pretty when new, but soon discolors unevenly; and brass knobs, although fashionable, require frequent rubbing to keep

Door-knobs.

them presentable. Glass knobs are clean and strong, and might with advantage be produced in a much greater variety of shapes and colors than can be found at present in the market; but as the glass must be set in metal, which will require occasional attention, there is no saving of trouble in using them. Wooden knobs, which were once very fashionable, and are still in use, have the disadvantage that the varnish with which they are coated becomes sticky and black with use, but they can be cleaned and revarnished in case of need. Celluloid is a good material, and would lend itself to the production of very beautiful effects; but, although colored celluloid knobs were once in limited use, the manufacture of them seems to have been abandoned.

INDEX

A

A, B, and C qualities, 166.
Absorption tiles, 99.
Adulterations of paint, 235.
Air-bound radiators, 89.
Air-chambers, 155.
Air-pipes, 140.
Air-supply, 67.
Ash floors, 217.
Automatic control, 54.

B

Back vents, 132.
Bad draught, 39.
Ball-cocks, 161.
Baltimore heater, 31.
Base-burner stoves, 32.
Baths, 117.
Bath-boilers, 135.
Bath-overflows, 119.
Battery, electric, 200.
Beams, floor, 4.
Bending chimneys, 19.
Birch floors, 218.
Blinds, sagging of, 263.
Blisters in paint, 252.
Blowers, 31.
Boilers, 43, 75.
Borders, floor, 214.
Brass pipe, 134.
Built, how a house is, 1.

Bulged plastering, 10.
Burglar alarms, 207.
By-pass, 140.

C

Care of fireplaces, 25.
Care of gas-fixtures, 195.
Care of plumbing, 173.
Care of woodwork, 209.
Cartridge paper, 246.
Ceilings, papered, 245.
Cesspools, 93.
Check-draught, 54.
Chimneys and fireplaces, 19.
Chimneys, decayed, 19.
Chimney-tops, 23.
China-gloss paint, 232.
City houses, 6.
Cleaning paint, 250.
Cleaning traps, 106.
Cleaning varnish, 252.
Cleaning wall-paper, 250.
Cleanouts in drains, 108.
Cleanouts in furnaces, 56.
Clinches, 9.
Clinkers, 63.
Clogging of cesspools, 94.
Cold-air box, 49.
Cold-water paint, 241.
Combination furnace, 65.
Composition roofs, 15.
Compression-cocks, 156.

Condensation, 88, 164.
 Construction, 2.
 Control, automatic, 54.
 Cracks in plastering, 8.
 Cutting glass, 267.

D

Dampers, 25.
 Defects in paint, 252.
 Defects in plastering, 9.
 Defective flues, 20.
 Direct draught, 53.
 Direct-indirect heating, 75.
 Direct steam heating, 74.
 Discoloration of paint, 232.
 Doors, faults of, 274.
 Door-knobs, 277.
 Down-draughts, 21.
 Drains, 103.
 Draught, bad, 39.
 Drip pipe, 87.

E

Earthenware, 180.
 Electric bells, 207.
 Electric gas-lighting, 199.
 Electrical fixtures, 198.
 Enamel paint, 231.
 Enamelled iron, 167.
 Evaporating pan, 57.
 Evaporation, 57.
 Expansion pipe, 137.

F

Faucets, 155.
 Finish, painted, 230.
 Fireplaces, 23.
 Fireplaces, smoky, 26.
 Flashings, 15.
 Flat roofs, 14.

Flatted paint, 232.
 Floor-boards, 4.
 Floor-borders, 214.
 Floors, 209.
 Floors, hardwood, 215.
 Floors, kitchen, 222.
 Floors, painted, 215.
 Floors, waxing, 219.
 Flues, 20.
 Flues, defective, 20.
 Flushing-tank, 101.
 Foot vent, 142.
 Freezing of radiators, 89.
 Fresco painting, 241.
 Frozen pipes, 175.
 Furnaces, 48.
 Furnace management, 64.
 Furring strips, 3.

G

Gas-keys, 191.
 Gas pipes and fixtures, 188.
 Georgia pine, 216.
 Girders, 3.
 Glass and glazing, 256.
 Glass setting, 265.
 Grates, 37.
 Grease in drains, 107.
 Ground-cocks, 156.

H

Hall registers, 70.
 Hammering in steam-pipes, 85.
 Hardwood floors, 215.
 Hearths, 26.
 Heating water, 43.
 Hot-air pipes, 66.
 Hot-water attachment, 65.
 Hot-water heating, 76.
 Hot-water pipes, 135.

Houses, city, 6.
 Houses, wooden, 2.

I

Imperfect circulation, 80.
 Incandescent lighting, 198.
 Indirect draught, 53.
 Indirect hot-water heating, 78.
 Indirect steam heating, 74.
 Iron sinks, 169.

J

Jacketed stoves, 32.
 Japanese wall-papers, 247.

K

Keeping a house in repair, 258.
 Key of plastering, 9.
 Kitchen floors, 222.
 Kitchen sink, 110.
 Kitchen stoves, 34.

L

Lacquering, 197.
 Laths, 3.
 Laundry wash-trays, 113.
 Leaks in gas-fixtures, 191.
 Leaky roofs, 16.
 Linseed oil, 237.
 Local vent, 129.

M

Main traps, 103.
 Maple floors, 217.
 Marble slabs, 171.
 Mildewing of paint, 235.

N

Needle-baths, 120.
 Nickel-plating, 134.

O

Oak floors, 218.
 Oil-finish paint, 232.
 Outside painting, 234.
 Overflow of drain, 95.
 Overflowing cesspool, 9t
 Overflows, 151.

P

Paint, china gloss, 232.
 Paint, defects in, 252.
 Paint, discoloration of, 232.
 Paint, enamel, 231.
 Paint, flatted, 232.
 Paint, oil-finish, 232.
 Painted finish, 230.
 Painted floors, 215.
 Painting plastered walls, 240.
 Pantry sink, 111.
 Papered ceilings, 245.
 Paste for wall-papers, 249.
 Peppermint test, 145.
 Pine floors, 209.
 Pipes, 133.
 Pitch of roofs, 14.
 Plastered walls, painting, 240.
 Plastering, bulged, 10.
 Plastering, defects in, 9.
 Plate glass, 256.
 Plumbing, 92.
 Poisonous colors, 247.
 Polarization of battery, 205.
 Potash treatment, 109.

R

Rafters, 3.
 Rats, 93.
 Rattling windows, 273.
 Ready-mixed paints, 238.
 Registers, 66.

Relief pipes, 87.
 Repairs of roofs, 17.
 Replating, 179.
 Roofs, 13.
 Roofs, composition, 15.
 Roofs, flat, 14.
 Roofs, pitch of, 14.
 Roofs, repairs of, 17.
 Roofs, shingle, 14.
 Roofs, slate, 13.
 Roofs, tile, 13.
 Round traps, 131.

S

Sashes, 254.
 Sash-fast, 273.
 Secondary circulation, 137.
 Setting glass, 265.
 Settlements, 6.
 Sewage pump, 96.
 Sewer-gas, 92.
 Sewer-traps, 105.
 Sewers, 93.
 Shaking a furnace, 62.
 Sheet-glass, 256.
 Shingle roofs, 14.
 Short-circuits, 203.
 Short hoppers, 121.
 Shower-baths, 120.
 Shrinkage, 7.
 Shutting off water, 157.
 Single-pipe steam heating, 84.
 Sinks, 110.
 Siphon-closets, 124.
 Siphon tank, 101.
 Size colors, 240.
 Slate roofs, 13.
 Smoky fireplaces, 26.
 Smyth grate, 62.
 Soapstone and slate, 167.
 Spruce floors, 210.

Staining floors, 210.
 Stains, 239.
 Stains in floors, 225.
 Standing finish, 229.
 Starting up the fire, 63.
 Steam and hot-water heating, 74
 Stippling, 243.
 Stoves and furnaces, 28.
 Stoves, kitchen, 34.
 Structural diseases, 6.
 Studs, 2.
 Subsoil irrigation, 97.

T

Testing for arsenic, 248.
 Testing for short-circuits, 203.
 Testing with peppermint, 145.
 Tile roofs, 13.
 Tilting-tank, 101.
 Timbers, weakness of, 8.
 Tin-lined pipes, 134.
 Traps, 130.
 Traps, cleaning, 106.
 Traps, main, 103.
 Traps of fixtures, 109.
 Troubles with plumbing, 139

V

Varnish, 240.
 Vitreous china, 127, 165.

W

Wall-papers, 243.
 Wash-basins, 115, 169.
 Wash-boilers, 115.
 Wash-down closets, 123.
 Washers, putting on, 157.
 Washing paint, 251.
 Washout closets, 128.

- Wash-trays, 113.
Water-closet cisterns, 130.
Water-closets, 121, 171.
Water-front, 36.
Water-hammer, 154.
Waxing floors, 219.
- Weakness of timbers, 8.
White lead, 234.
Window cords, 269.
Window sashes, 254.
Wooden houses, 2.
Woodwork, care of, 209.

UNIVERSITY OF CALIFORNIA LIBRARY
BERKELEY

Return to desk from which borrowed.
This book is DUE on the last date stamped below.

JAN 2 1948

24 May '49 HJ

LD 21-100m-9,'47(A5702s16)476

YB 10807



401354

TH8901

Clark @6

UNIVERSITY OF CALIFORNIA LIBRARY

